

Ei.H008KL-012KL

Single-phase Hybrid Inverter (Low voltage)

User Manual

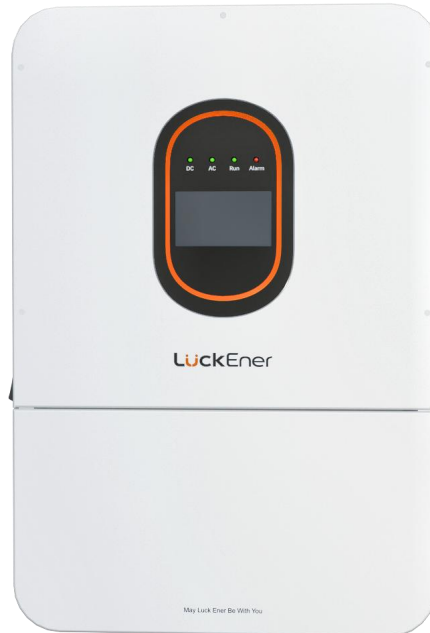

Catalogue

1. Information on this Manual	1
1.1 Scope of Validity	1
1.2 Statement	1
1.3 Safety instruction	1
2. Product Introductions	3
2.1 Product Appearance	3
2.2 Product Features	6
3. Installation Guide	7
3.1 Packaging	7
3.2 Tool Preparation	8
3.3 Installation Environment Requirements	8
3.4 Mounting Procedure	9
3.5 Electrical Connections	10
3.5.1 PV Connection	11
3.5.2 Battery Connection	14
3.5.3 AC Connection	16
3.5.4 Grounding	17
3.5.5 Communication Connection	18
3.5.6 Communication Ports	22
3.5.7 Wiring Diagram	25
4. Operation	26
4.1 Power ON/OFF	26
4.2 Display Panel	26
4.3 LED Indicators	27
4.4 LCD Screen Interface	28
4.4.1 System Working Flow Chart	28
4.4.2 Display Information	29
4.4.3 Parameters Setting	30
4.4.4 Basic Setting	30
4.4.5 Battery Setting	31
4.4.6 Mode Setting	35
4.4.7 Grid Setting	38
4.4.8 GEN Port Setting	39
4.4.9 Advanced Setting	41
5. Maintenance	42
5.1 Routine Care	44
5.2 Safety Notes for Maintenance	44
6. Troubleshooting	45
7. Specification	48

1. Information on this Manual

1.1 Scope of Validity

This manual is an integral part of the hybrid inverter (Hereinafter in this manual referred to as “inverter” or “product” or “device”), which describes the assembly, installation, commissioning, maintenance and troubleshooting of the following models of products:

Ei.H008KL-A1.23-P1NV-L; Ei.H010KL-A1.23-P1NV-L; Ei.H012KL-A1.34-P1NV-L;
Ei.H008KL-A2.23-P1NV-L; Ei.H010KL-A2.23-P1NV-L; Ei.H012KL-A2.34-P1NV-L;



Note: Please keep this manual where it will be accessible at all times.

1.2 Statement

Due to ongoing product improvements, Jiangsu LT Technology Co., Ltd.(Hereinafter in this manual referred to as LT) reserves the right to modify product features and specifications at any time without prior notice. The latest version of this manual is available on the official website (www.lt-ess.com). Although great care has been taken to ensure accuracy, LT assumes no responsibility for any errors, omissions, or damages—whether direct, indirect, or consequential—arising from the use of this document or from outdated information it may contain.

LT shall not be held liable for any losses resulting from improper installation, incorrect operation, or compatibility issues involving third-party systems. The responsibility for correct installation and compliance with local regulations rests solely with the customer.

Any unauthorized hardware or software alterations, repairs, or modifications will immediately void the product warranty.

LT accepts no responsibility for damage or malfunction caused by misuse, mishandling, or failure to follow the safety instruction. This device operates at potentially lethal voltages and must only be installed by professionals who are qualified in operating high-voltage equipment.

1.3 Safety instruction







This section contains important information of safety and operating precautions. Read and save this manual for future reference. Before installing and operating this device, please thoroughly read all instructions in this manual and check warning signs on the device. Make sure you understand the working mechanism of inverter and all relevant sections in this manual.

Before installation, users must ensure that:

- Adequate space and ventilation are available for safe equipment operation.
- Environmental noise and potential fire risks have been properly considered and evaluated.
- The device is operated only under permissible environmental and transportation conditions.

- Maintenance could be performed correctly and regularly only by qualified personnel.
- The device is not tampered with, improperly repaired by, or installed by unqualified individuals.

The following label instructions appear in this document and inverter as described below:

	<p>The inverter can not be disposed together with the household waste. Disposal information can be found in the enclosed documentation.</p>
	<p>Warning! Attention and cautions are called! Operations might cause equipment damage or human injuries!</p>
	<p>Beware of hot surface. The energy station can become hot during operation. Avoid contact during operation.</p>
	<p>Danger to life due to high voltage. There is residual voltage existing in the inverter after powering off, which needs 5 min to discharge. Wait 5 minutes before you open the upper lid or the DC lid.</p>
	<p>Danger of high voltages and electric shock! Danger to life due to high voltages in the inverter!</p>
	<p>Please refer to the instructions carefully before use.</p>
	<p>Symbol Explanation CE mark. The energy station complies with the requirements of the applicable CE guidelines.</p>

2. Product Introductions

2.1 Product Appearance

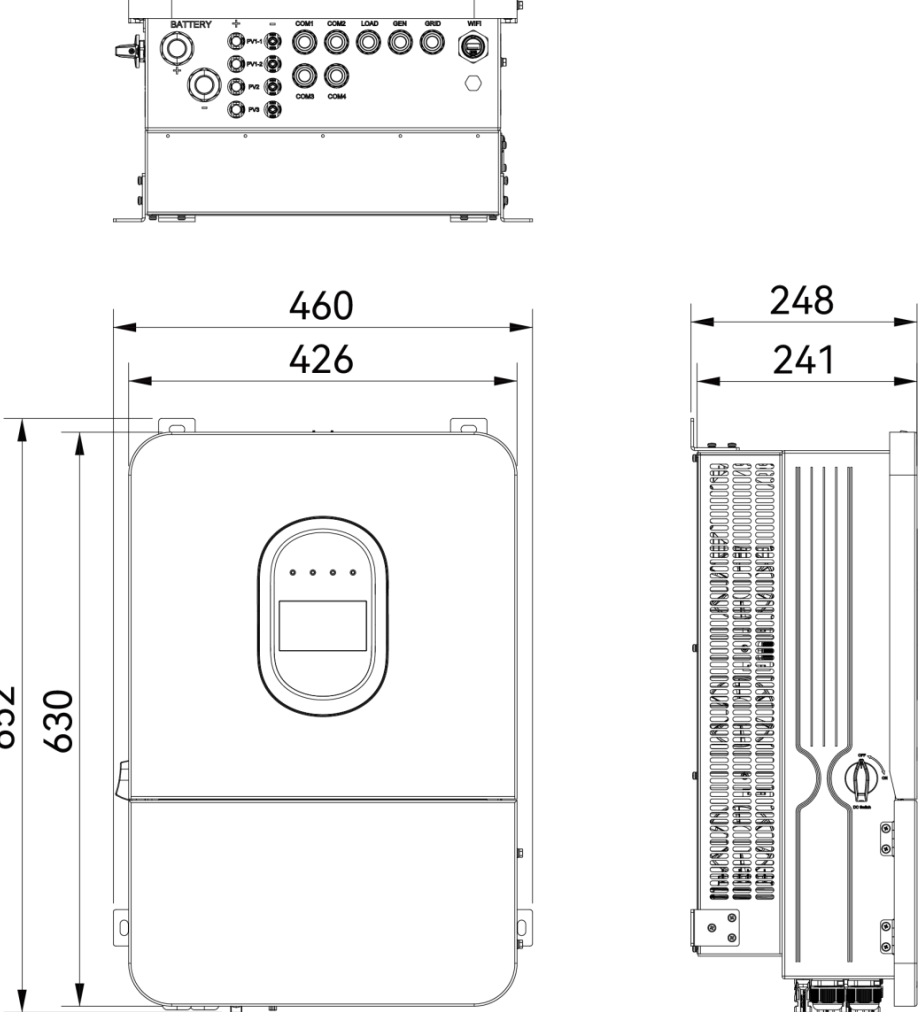
Model	Appearance
Ei.H008KL-A1.23-P1NV-L; Ei.H010KL-A1.23-P1NV-L; Ei.H012KL-A1.34-P1NV-L;	 <p>The technical drawing illustrates the product's appearance from three perspectives: front, top, and side views. The front view shows a rectangular unit with a central oval-shaped display or indicator panel. The top view shows the terminal block with labels: BATTERY, PV+1, PV-1, PV+2, PV-2, PV+, PV-, COM1, COM2, COM3, COM4, LOAD, GEN, GRID, and VFI. The side view shows the depth of the unit. Dimensions are provided in millimeters: front view height is 652mm (total) and 630mm (main body); top view width is 460mm (total) and 426mm (main body); side view depth is 248mm (total) and 241mm (main body).</p>

Ei.H008KL-A2.23-P1NV-L;
Ei.H010KL-A2.23-P1NV-L;
Ei.H012KL-A2.34-P1NV-L;

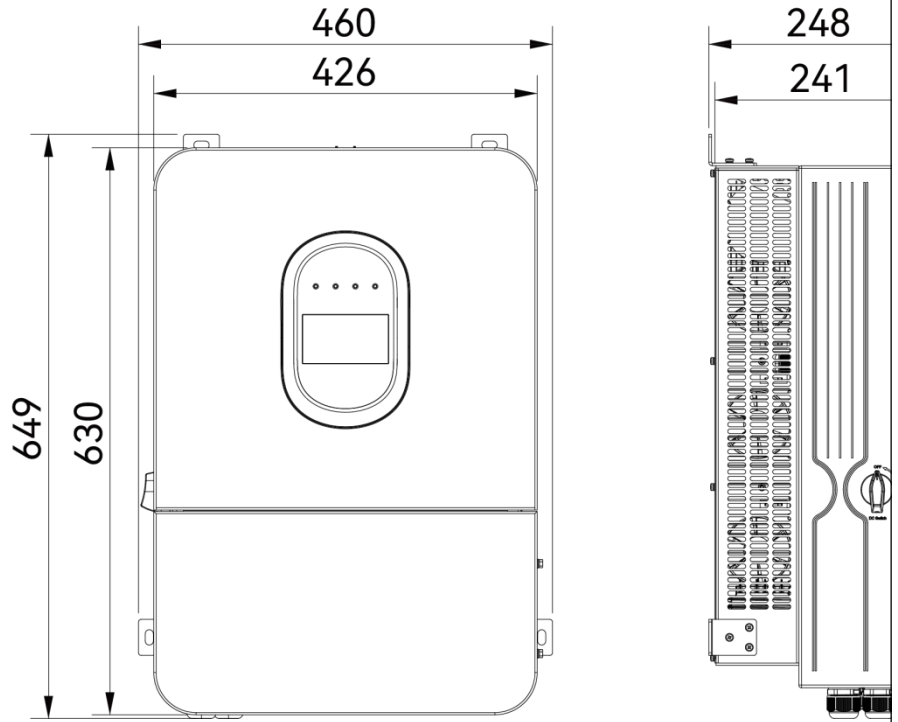
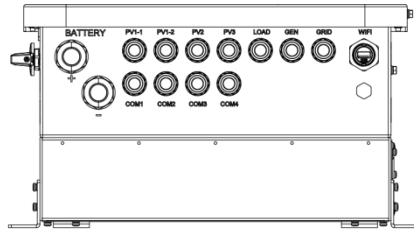

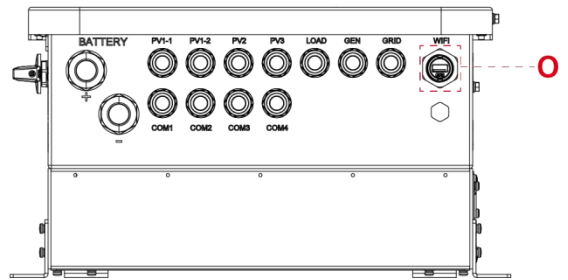
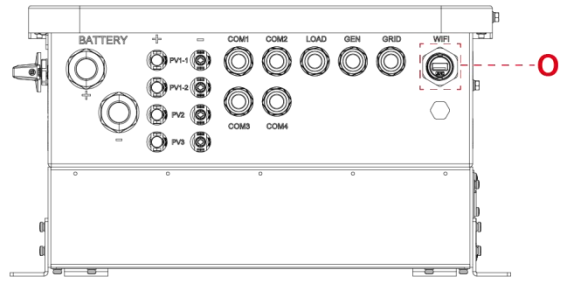
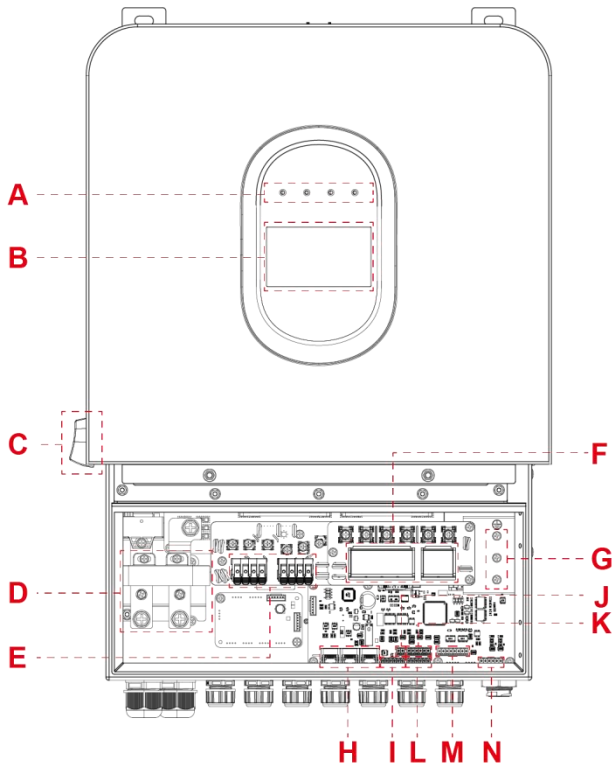

A: Inverter LED Indicators	F: AC Connection (Load/GEN/Grid)	K:RS485/Temperature Detection of Lead-acid Battery
B: LCD Display	G: Earth Connection	L: RS485
C: DC Switch	H: BMS/PAL CAN	M: DRED/RCR
D: Battery Connection	I: Gen	N: CT
E: PV Connection	J: RSD_P	O: WiFi Interface

2.2 Product Features

The LT Hybrid Inverter is designed with the advanced technology in field to manage power resources and loads in an efficient and safe manner. Some features of the inverter are but not limited to:

- color touchscreen, intuitive interface, and effortless control
- Support 200% DC/AC ratio for maximum utilization
- Up to 3 MPPTs and maximum 40A input current, compatible with the latest all PV modules
- Support 200% overload for 10 seconds, ensuring reliable startup of inductive loads
- Switching time <10 ms, ensuring seamless transition between on-grid and off-grid modes
- AC coupling compatibility for flexible system expansion
- Support up to 240A charging and discharging current, ensuring fast charging and discharging operation during peak hours
- Support off-grid operation without battery, offering flexible design and reducing initial investment costs
- Support flexible battery configuration, allowing users to select the most suitable capacity
- Export power control, ensuring precise management of grid feed-in to meet local requirements
- Up to 6 units in off-grid parallel operation, ensuring flexible and reliable energy system configuration
- IP66 protection rating, ensuring reliable operation in harsh environmental conditions

3. Installation Guide

3.1 Packaging

Before starting installation, check that all accessories are included and in good condition.

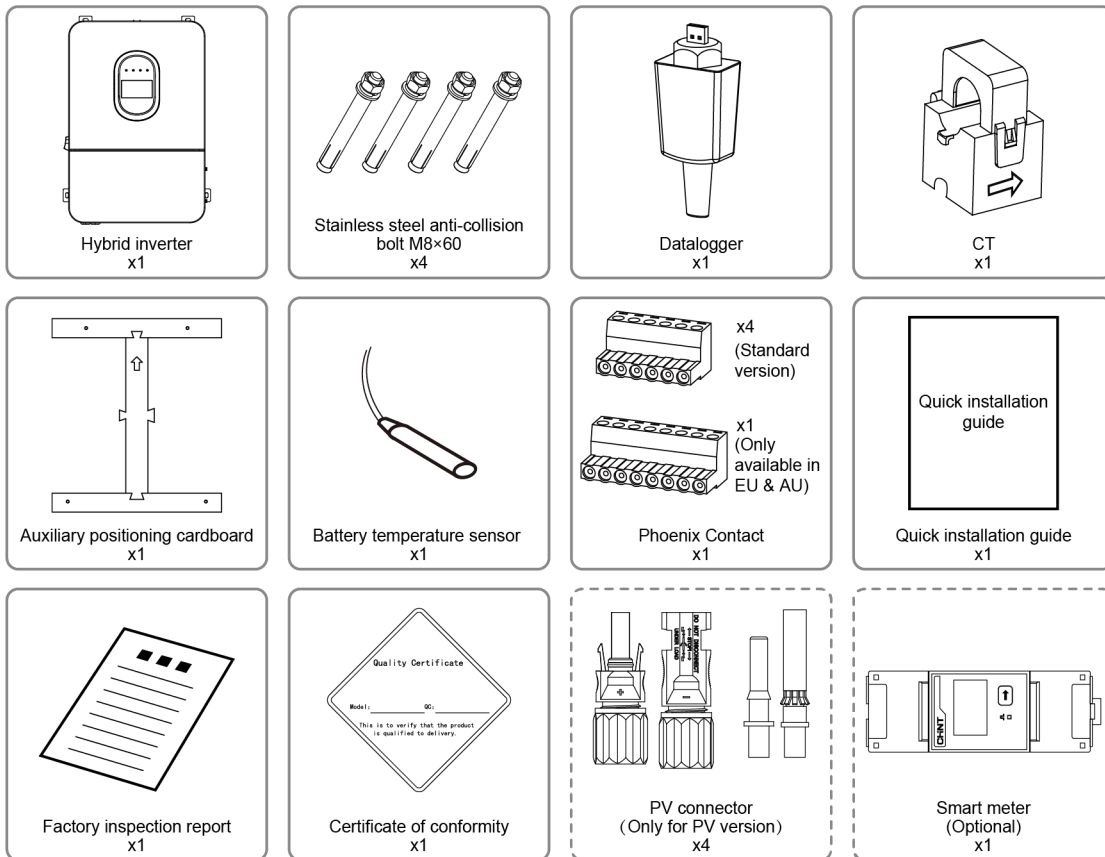

3.2 Tool Preparation



3.3 Installation Environment Requirements

To ensure reliable and safe operation, select a suitable installation site:

- Mount the inverter vertically on a strong, flat wall.
- Avoid locations enduring direct sunlight, rain, snow and high humidity.
- Ensure good ventilation and clearance around the inverter:
 - Top&Bottom&Sides: ≥ 500 mm
 - Front: ≥ 1000 mm
- Ambient temperature range: -25 °C to $+60$ °C
- Avoid installation in areas with corrosive gas, conductive dust, or strong vibration.
- Ensure that surrounding objects and surfaces follow the clearance distances indicated in the diagram to allow proper heat dissipation and sufficient space for moving the cables.

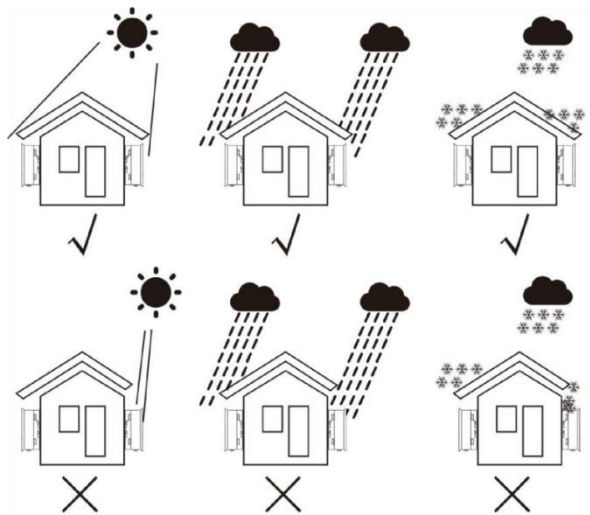
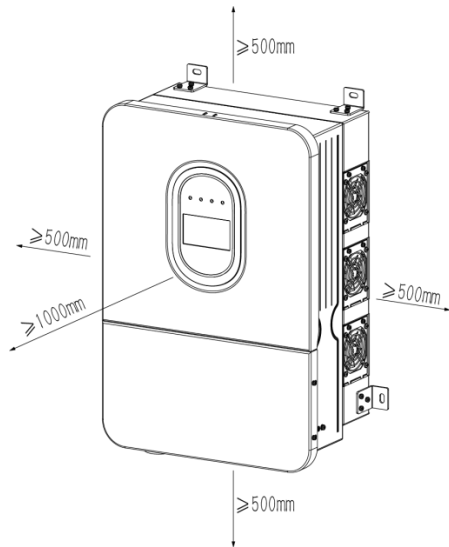

3.4 Mounting Procedure

1. Use the auxiliary positioning cardboard to mark the drilling points on the wall or mounting surface.
2. Drill holes at the marked points and insert expansion bolts.
3. Loosen the screws and remove both the screws and the washers.
4. Lift the inverter, position it at the marked points, and secure it by tightening the screws and washers.
5. Check that the inverter is level and stable.

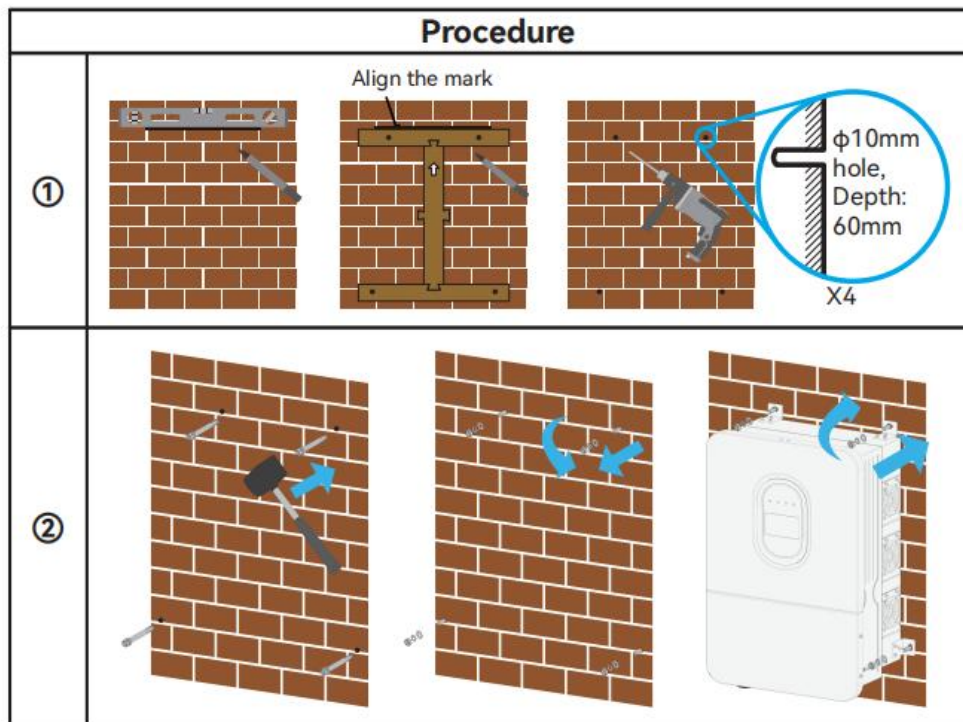



Warning: Two persons are recommended when lifting the inverter to avoid injury or damage.



Note: Loosely tighten the four screws first to hang the inverter. Then slightly adjust the inverter to the good position before diagonally tightening the screws completely.

3.5 Electrical Connections

Before starting the electrical installation, please be aware of the following precautions.

- The cables used for electrical connections must be dedicated photovoltaic (PV) cables. All electrical connections must comply with local electrical regulations.
- All wiring and cabling processes must be performed by qualified personnel.
- Always keep the breakers of the source side (PV, battery, grid, and generator) in status of switched off during the installation process.
- Always keep the DC switch on the left side of the inverter in status of switched off during the installation process. See section 2.1 to find the position of DC switch.
- Verify and double confirm that the PV and battery inputs are connected to the inverter with the correct polarity.
- Verify and double confirm that all the voltages at the connecting point (PV input, battery input, generator input, grid connection) are in the valid range of the inverter. See specification to find the voltage range.
- Verify and double confirm that all the wires and cables are in good electrical condition before installation.

The following specifications are only recommended values. Cable selection should be based on the actual cable length, current requirements of the application, local regulations and applicable electrical safety standards.

No.	Type	Recommend Cable
1.	Grounding connection	10mm ² OR 6AWG
2.	Battery connection	70mm ² OR 3/0AWG
3.	PV connection	4mm ² OR 12AWG
4.	AC connection-Grid;Load	16mm ² OR 4AWG
5.	AC connection-Gen	10mm ² OR 6AWG



Warning: Always use a protective breaker if applicable and keep the breaker in disconnected status during electrical connection.



Warning: Always measure terminal voltage and confirm the reading is 0 before electrical connection. DO NOT make electrical connection with live voltage!



Warning: Be cautious to prevent accidentally shorting any AC terminals (L-N or L-L) or DC terminals (positive-negative) during electrical connection.

3.5.1 PV Connection

The inverter has a few sets of MPPT connections for PV input. Please be aware of the following operations during PV connection.

- Always keep the DC switch of the inverter in the status of OFF during the PV connection process. See section 2.1 to find the position of DC switch.
- Do not connect the PV string to or disconnect the PV string from the inverter immediately after the inverter stops working. Always wait 5 minutes for inverter to discharge residual energies before any operations.
- Confirm that the PV string voltage does not exceed the inverter's maximum DC input voltage. See specification to find the PV input voltage range of the inverter for your model.
- Confirm whether your model has MC4 connectors before starting the connection. See the bottom of your inverter to determine and refer to the pictures below for connecting with MC4 connectors. You need specialized parts and a wrench to make MC4 connectors for both positive and negative PV cables if the model has MC4 connectors. If not, simply connect the wire to the corresponding position shown in the picture below.
- Each PV string should have an independent DC fuse and breaker.
- Ensure the total PV power does not exceed the inverter's PV input limit. See specification to find the PV input power limit for the inverter.

- Use colored cables and confirm the correct connection of polarity (positive to positive, negative to negative).

Ei.H008KL-A1.23-P1NV-L; Ei.H010KL-A1.23-P1NV-L; Ei.H012KL-A1.34-P1NV-L;

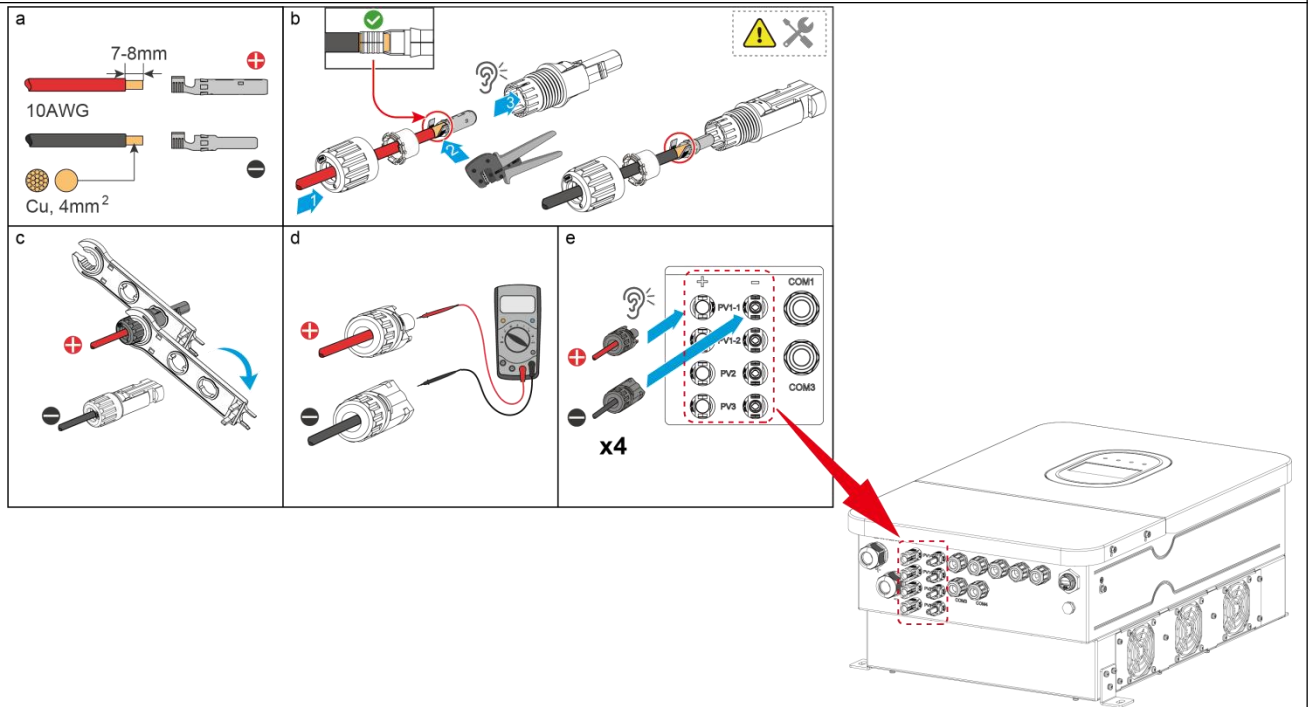

Ei.H008KL-A2.23-P1NV-L; Ei.H010KL-A2.23-P1NV-L; Ei.H012KL-A2.34-P1NV-L;

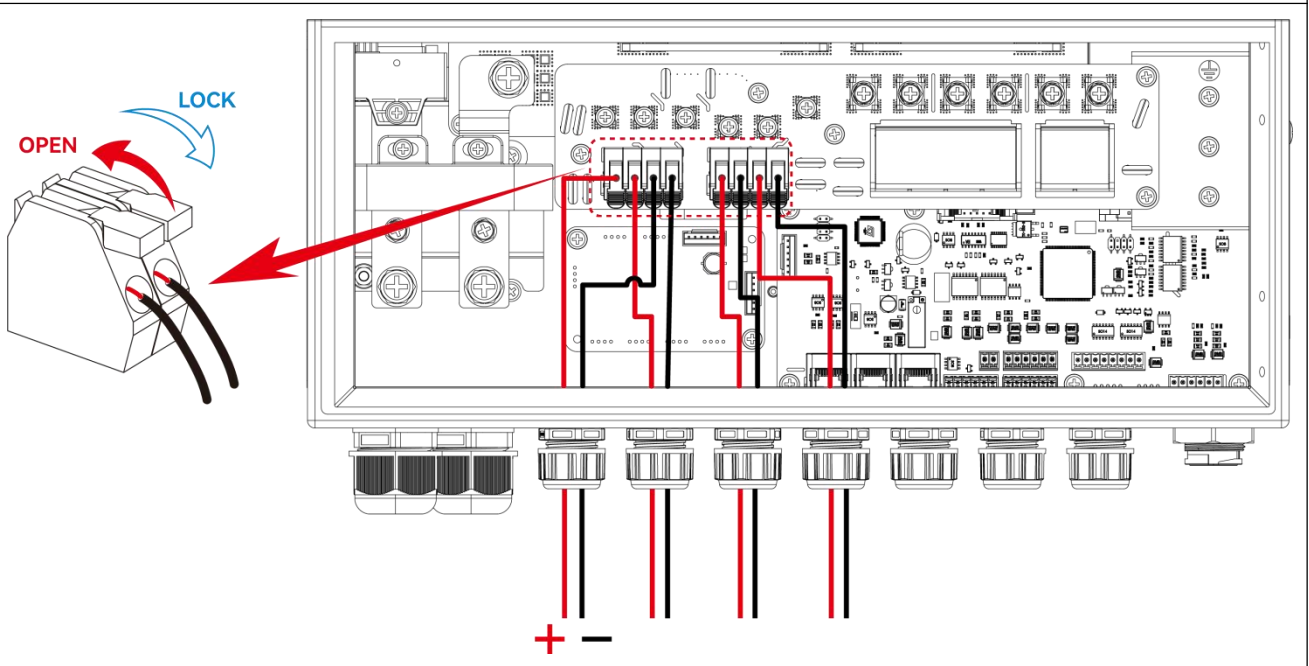



Danger: DO NOT disconnect the PV string from the inverter when there is DC current to avoid generating DC arc.



Danger: Always confirm the DC switch of the inverter is in the status of OFF before connecting or disconnecting the PV string from the inverter.



Danger: Be cautious to prevent accidentally shorting positive and negative terminal of PV string during PV connection.

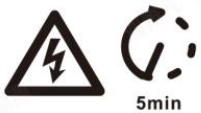

Danger: DO NOT connect the PV string to or disconnect the PV string from the inverter immediately after the inverter stops working. Always wait 5 minutes for inverter to discharge residual energy before any operations.



Warning: Always keep the protective breaker (if applicable) in disconnected position during PV connection!

3.5.2 Battery Connection

Battery is the energy storage unit in a hybrid system. The product can connect to both lead-acid type and lithium-ion type. Please be aware of the following operations during connection of the battery.

- Confirm battery type and voltage range are compatible with the inverter before selecting and installing the battery. See specification to find compatible battery data for your model.
- Use colored cables and confirm the correct connection of polarity (positive to positive, negative to negative).
- Connect through a DC breaker near the battery.
- Connect the BMS communication cable securely for lithium-ion battery, if applicable.
- Connect the temperature sensor cable for lead-acid battery, if application.
- Tighten all terminals to avoid heating or sparking.
- Use correctly rated cables and connecting terminals.
- Be cautious to prevent accidentally shorting positive and negative of battery during battery connection.
- Always keep the protective breaker (if applicable) in disconnected position during battery connection. Recommended terminal (Square tongue terminals)

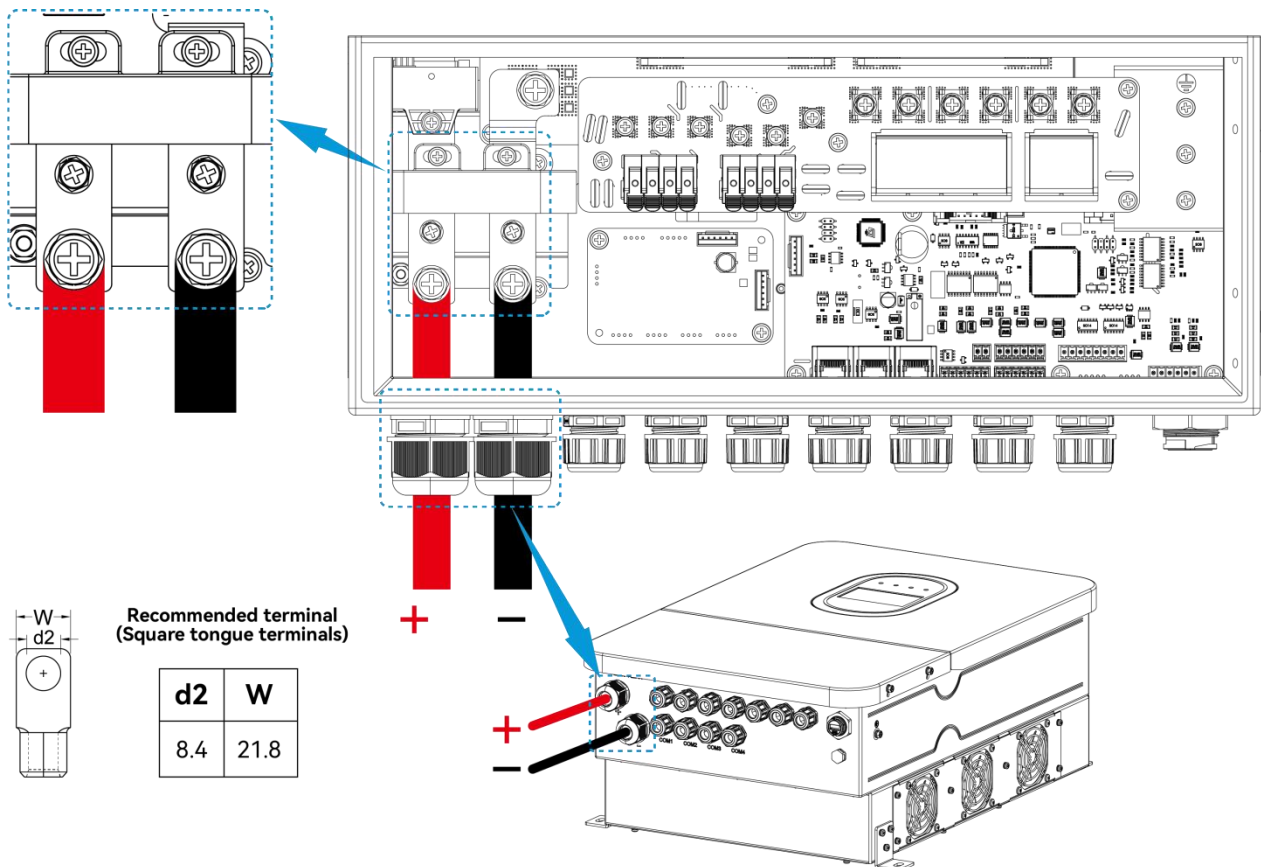



Danger: Be cautious to prevent accidentally shorting positive and negative terminal of battery during battery connection.



Danger: Be cautious to select the battery. Confirm battery terminal voltage is not higher than the permissible input voltage range of the inverter before battery connection.



Warning: Always keep the protective breaker (if applicable) in disconnected position during battery connection!

3.5.3 AC Connection

There are three AC connections in the inverter: AC connection for grid, AC connection for backup load and AC connection for generator input. Please be aware of the following operations during the AC connection.

- Confirm AC voltage range are compatible with the inverter before connection. See specification to find AC voltage range for your model.
- Connect the AC output/input (grid), AC output (backup) and AC input (GEN) according to the labels. Do not mix the connections.
- Critical loads are connected to AC output (backup). Generator or normal loads are connected to AC input (GEN). Confirm the application scenario of your case before the connection.
- Confirm the phase and neutral lines are connected correctly.
- Use correctly rated cables, connecting terminals and protective breakers.
- Use colored cables and confirm L cable and N cable are connecting to the right terminal.
- Be cautious to prevent accidentally shorting the L cable and N cable during AC connection.
- Always measure the L-N voltage and confirm the reading is 0V before AC connection or disconnection.

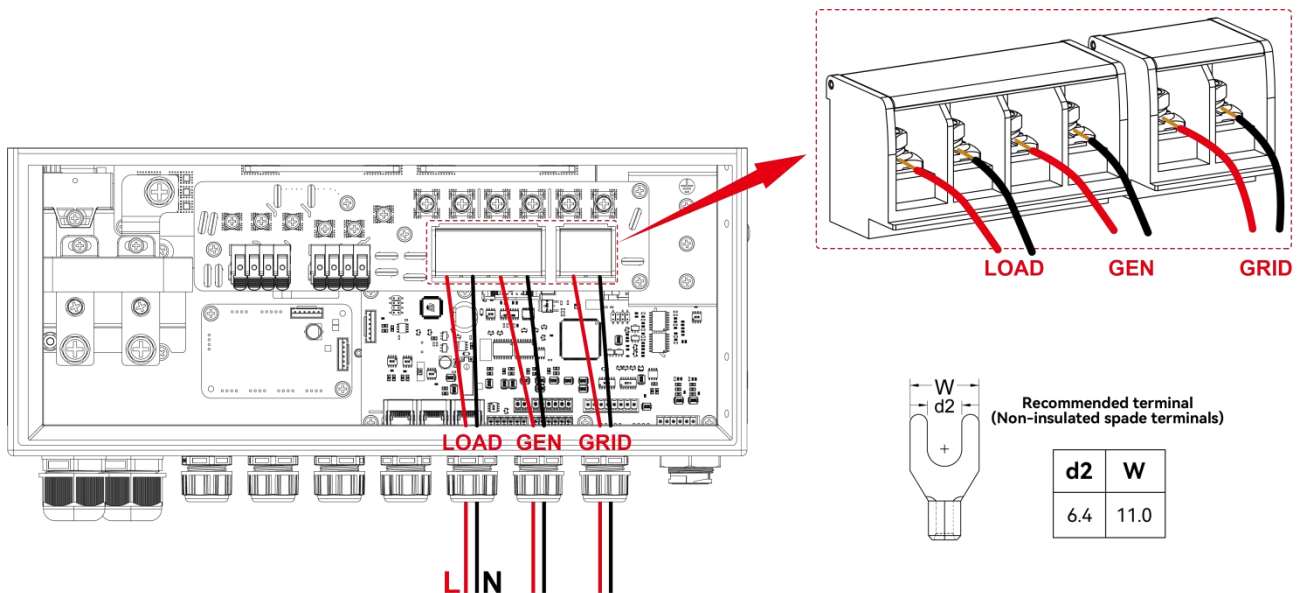

Note: In countries or regions such as the Philippines, two live (phase) wires may be present. During wiring, please ensure that the connection order of different ports is consistent (L1–L; L2–N).



Danger: Be cautious to prevent accidentally shorting the L-N cable or L-L cable during AC connection.



Danger: DO NOT make AC connection when there is live voltage. Always measure the L-N voltage and confirm reading is 0 before AC connection or disconnection.



Warning: Always keep the protective breaker (if applicable) in disconnected position during AC connection!

3.5.4 Grounding

Please be aware of the following operations during earth connection.

- Always connect the PE (Protective Earth) terminal to a reliable earth ground.
- Ground the PV frame and AC distribution circuit according to local standards.
- Ensure all grounding points are tight and corrosion-free.

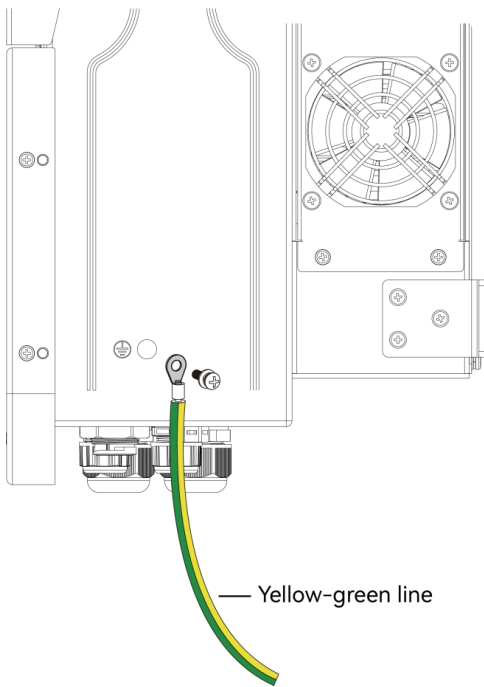
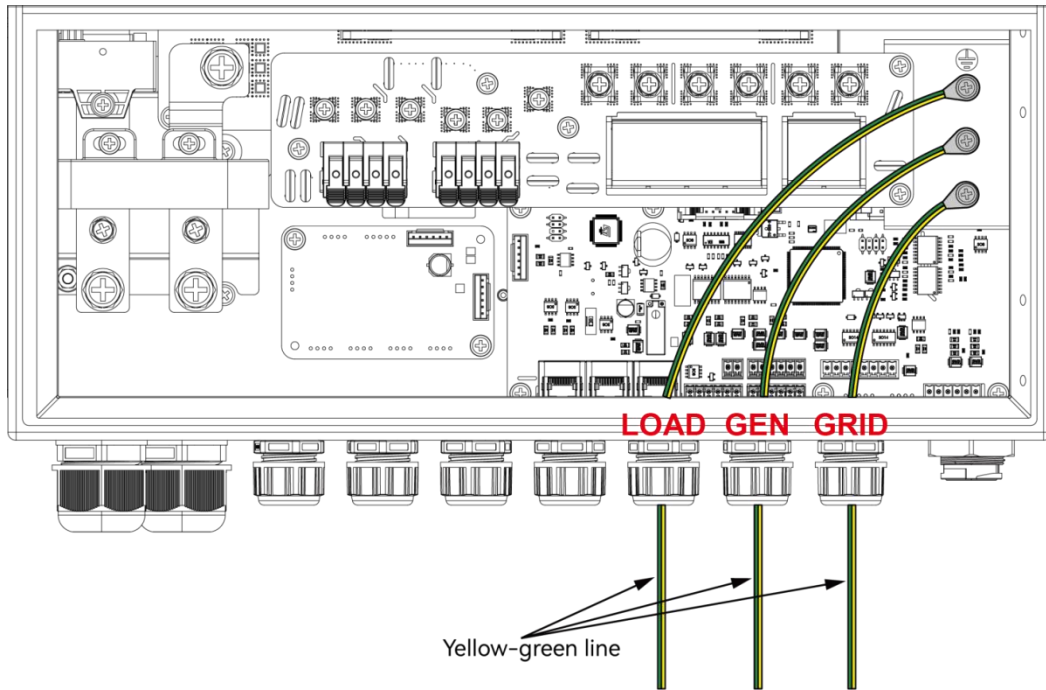

3.5.5 Communication Connection



LT Commitment

1. We only collect and use device data to enhance product quality and service.
2. All data is securely stored and will not be shared with any third party.
3. Users may request to disable this function without affecting normal inverter operation.

3.5.5.1 Data logger

Install the data logger as shown in the diagram. Tighten connectors and ensure waterproof seals are in place.

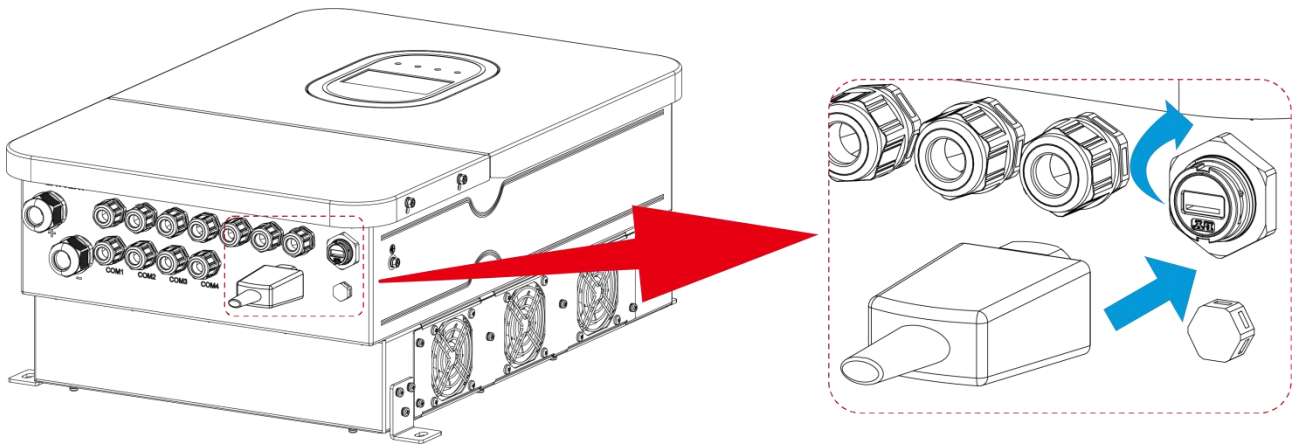

3.5.5.2 Battery Management System Connection for Lithium Ion Battery

If the inverter is connecting to a lithium ion battery set, the battery management system (BMS) is necessary to communicate with the inverter. Confirm the BMS communication cable from the battery is connected to the right port of the inverter. And also confirm that both BMS and inverter share the same communication protocol so that they could understand each other.

3.5.5.3 Temperature Sensor Connection for Lead-acid Battery

If the inverter is connecting to a lead-acid battery set, it is necessary to connect the temperature sensor for measuring and monitoring the temperature of the battery. See the accessories to find the temperature sensor for your model and confirm it is connected to the right communication port as shown in the following picture.

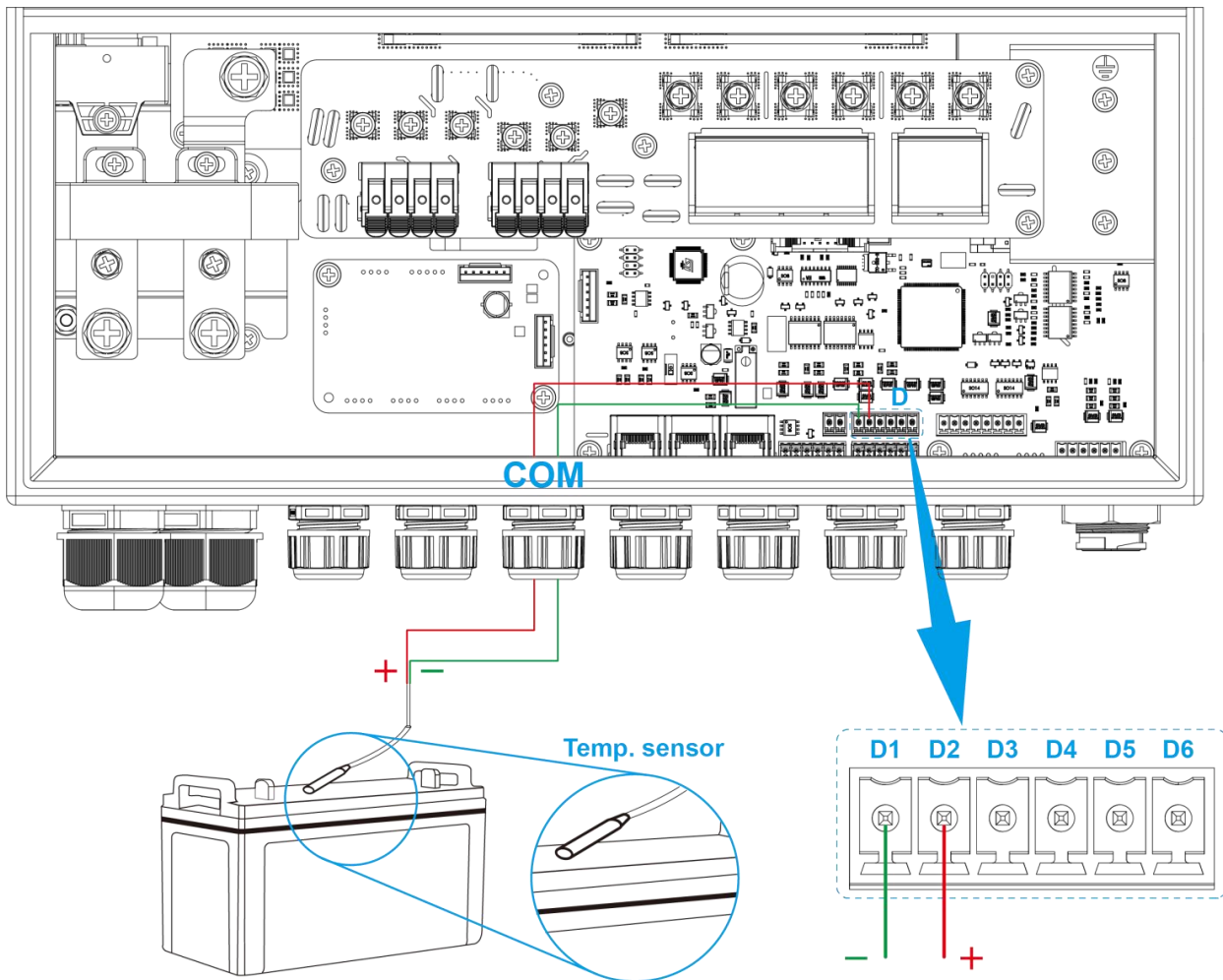

3.5.5.4 CT/Smart Meter Connection

To enable export limitation and energy monitoring functions, the inverter supports connection of **Current Transformer (CT)** or **Smart Meter**.

Connection Method:

- CT/smart metre must be installed on the **grid side** of the AC input.
- Ensure the direction of measurement follows the current flow from the inverter to the grid.
- Connect the communication wires between the inverter and CT/smart metre according to terminal labels.
- Keep communication cables as short as possible (recommended < 10 m).

Typical Functions:

- Real-time monitoring of grid import and export power.
- Power limitation (Zero-Export mode).

- Load consumption statistics.

CT:

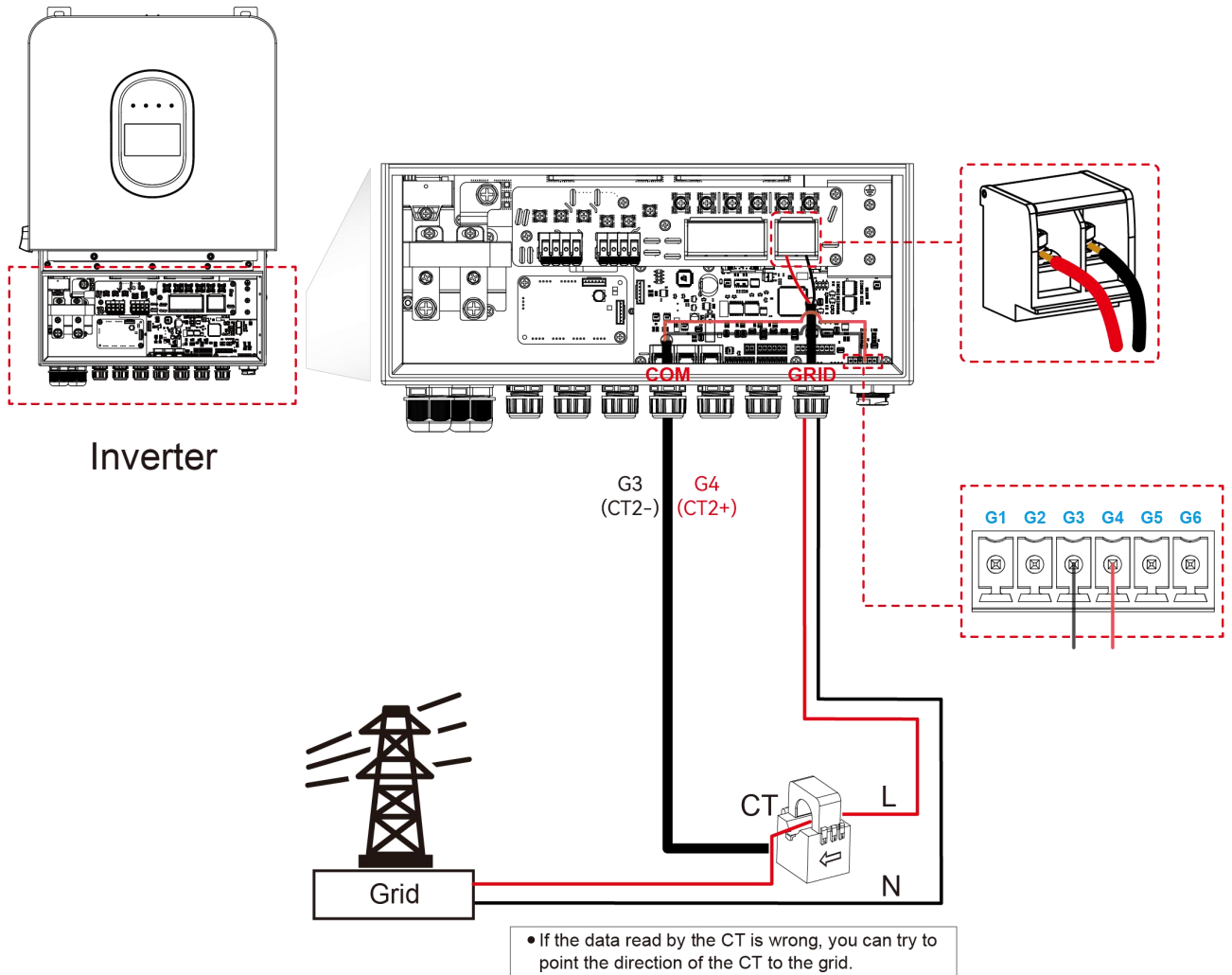

Smart Meter:

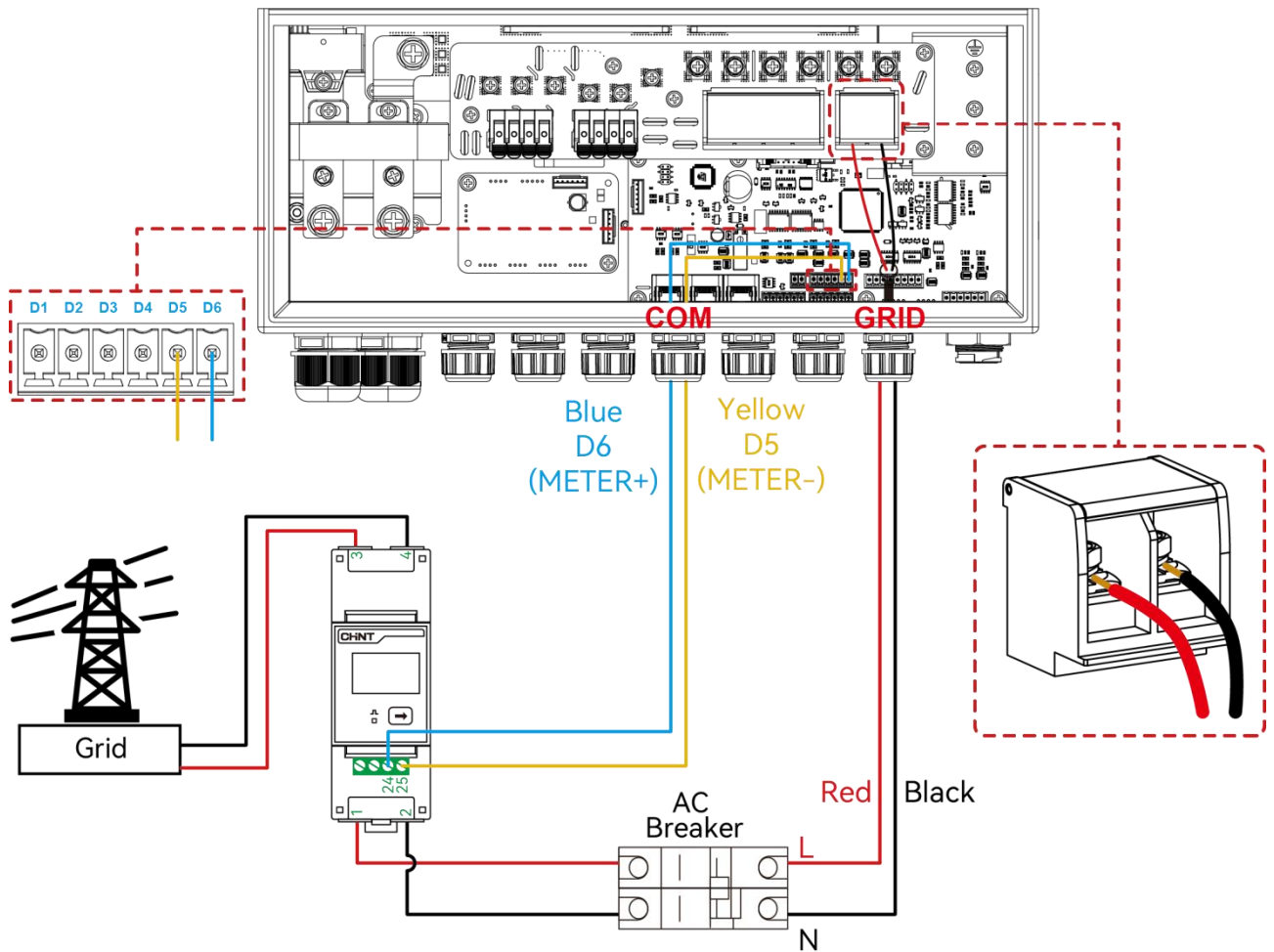

3.5.6 Communication Ports



LT Commitment

4. We only collect and use device data to enhance product quality and service.
5. All data is securely stored and will not be shared with any third party.
6. Users may request to disable this function without affecting normal inverter operation.

Some devices and functions require communication with the inverter, such as **the battery, CT, GEN, and parallel operation**. Please connect these communication interfaces to the inverter according to the table below. To minimize interference, avoid routing communication cables parallel to power cables.

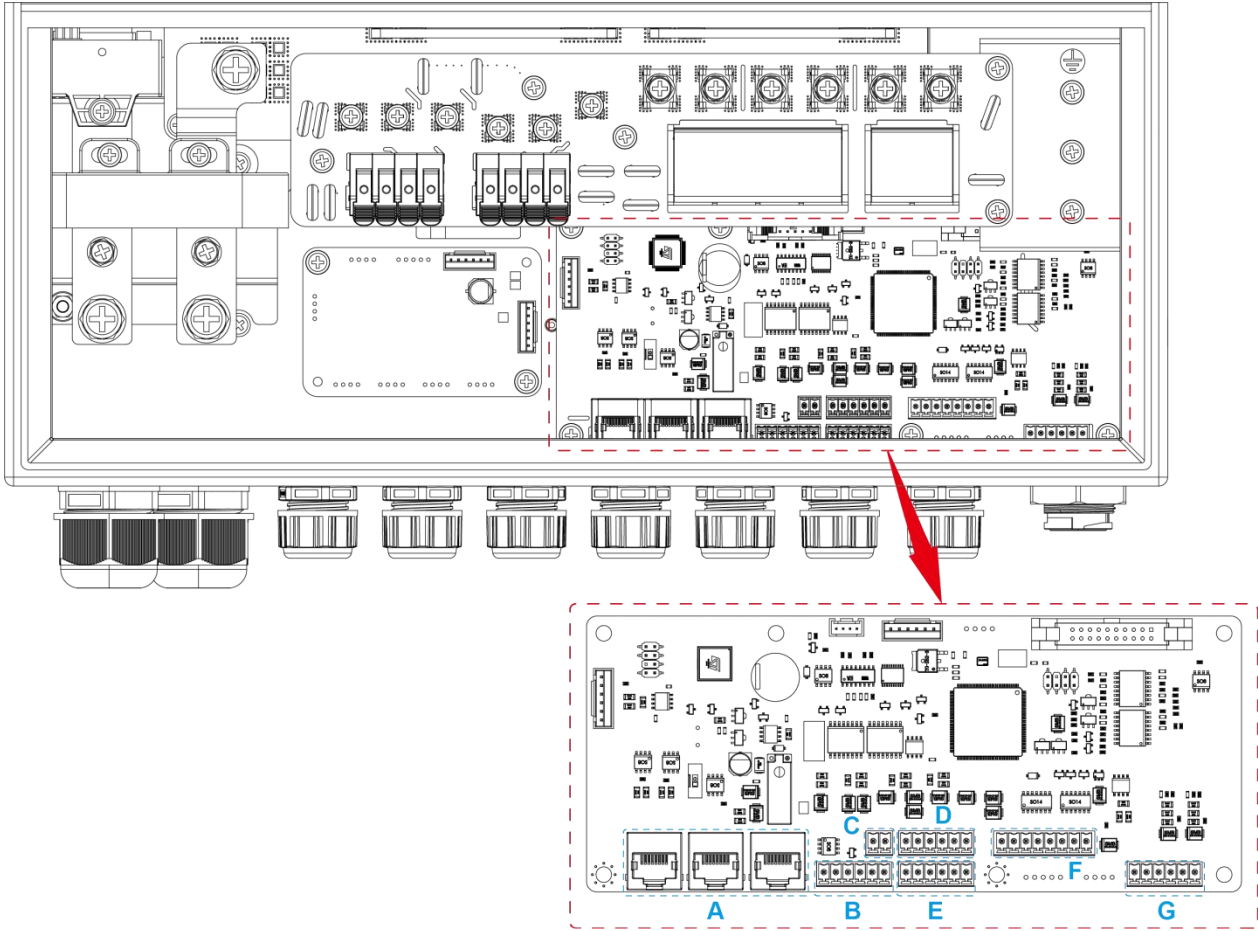

Block No.	Block name	Diagram	Port No.	Port	Terminal type																																				
A	BMS/PAL CAN	 <table border="1"> <thead> <tr> <th>Port No.</th> <th>Pin 8</th> <th>Pin 7</th> <th>Pin 6</th> <th>Pin 5</th> <th>Pin 4</th> <th>Pin 3</th> <th>Pin 2</th> <th>Pin 1</th> </tr> </thead> <tbody> <tr> <td>A1</td> <td>/</td> <td>/</td> <td>/</td> <td>BMS_CANL1</td> <td>BMS_CANH1</td> <td>/</td> <td>/</td> <td>/</td> </tr> <tr> <td>A2</td> <td>SYN_BUS_2</td> <td>SYN_BUS_1</td> <td>GND_S</td> <td>PAL_CANL</td> <td>PAL_CANH</td> <td>/</td> <td>/</td> <td>/</td> </tr> <tr> <td>A3</td> <td>SYN_BUS_2</td> <td>SYN_BUS_1</td> <td>GND_S</td> <td>PAL_CANL</td> <td>PAL_CANH</td> <td>/</td> <td>/</td> <td>/</td> </tr> </tbody> </table>	Port No.	Pin 8	Pin 7	Pin 6	Pin 5	Pin 4	Pin 3	Pin 2	Pin 1	A1	/	/	/	BMS_CANL1	BMS_CANH1	/	/	/	A2	SYN_BUS_2	SYN_BUS_1	GND_S	PAL_CANL	PAL_CANH	/	/	/	A3	SYN_BUS_2	SYN_BUS_1	GND_S	PAL_CANL	PAL_CANH	/	/	/	A1	BMS_CAN 1&CAN2	
			Port No.	Pin 8	Pin 7	Pin 6	Pin 5	Pin 4	Pin 3	Pin 2	Pin 1																														
			A1	/	/	/	BMS_CANL1	BMS_CANH1	/	/	/																														
A2	SYN_BUS_2	SYN_BUS_1	GND_S	PAL_CANL	PAL_CANH	/	/	/																																	
A3	SYN_BUS_2	SYN_BUS_1	GND_S	PAL_CANL	PAL_CANH	/	/	/																																	
A2	PAL_A																																								
A3	PAL_B																																								
B	Gen		B1	Gen-																																					
			B2	Gen+																																					
			B3	GNDS																																					
			B4	IOin2																																					

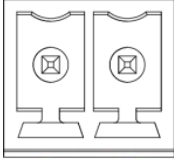
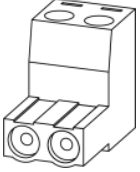
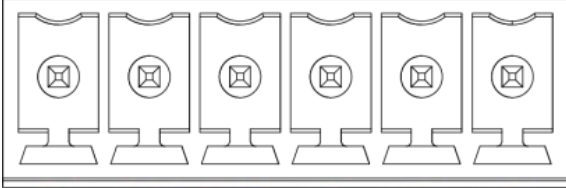
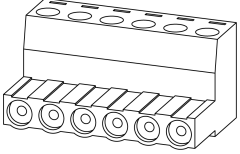
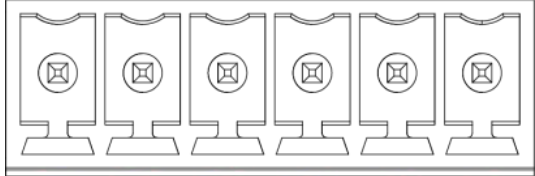
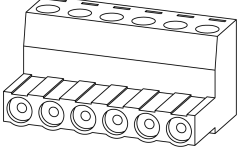
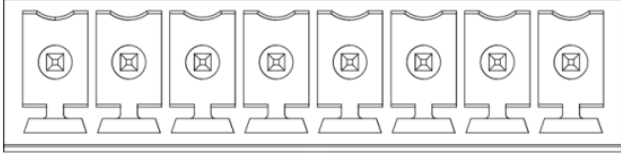
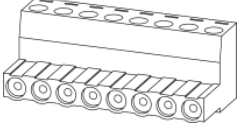
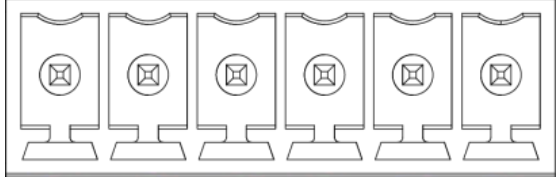
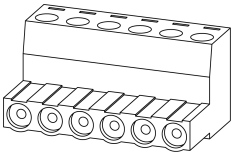
			B5	IOin1	
			B6	GNDS	
C	RSD_P	 <p style="text-align: center;">C1 C2</p>	C1	GNDS	
			C2	12VS1	
D	RS485/Temperature detection of lead-acid battery	 <p style="text-align: center;">D1 D2 D3 D4 D5 D6</p>	D1	GNDS	
			D2	La_Temp	
			D3	EMS-	
			D4	EMS+	
			D5	METER-	
			D6	METER+	
E	RS485	 <p style="text-align: center;">E1 E2 E3 E4 E5 E6</p>	E1	GNDS	
			E2	NC	
			E3	BMS2-	
			E4	BMS2+	
			E5	BMS1-	
			E6	BMS1+	
F	DRED/RCR	 <p style="text-align: center;">F</p>	F	DRED/RCR	
G	CT	 <p style="text-align: center;">G1 G2 G3 G4 G5 G6</p>	G1	-	
			G2	-	
			G3	CT2-	
			G4	CT2+	
			G5	CT1-	
			G6	CT1+	

3.5.7 Wiring Diagram

The diagram below is an example for an application in which neutral is separated from the PE in the distribution box. For countries such as China, Germany, the Czech Republic, Italy, etc, please follow local wiring regulations.

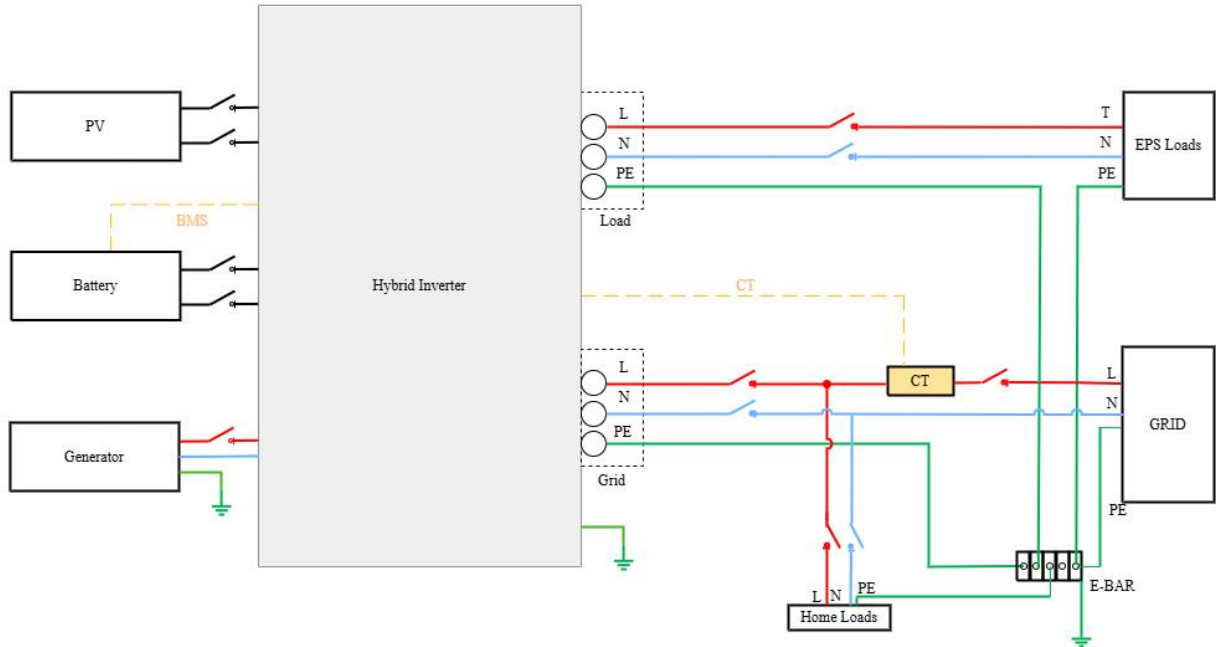

The diagram below illustrates an example where the neutral is connected to the PE in a distribution box. For countries like Australia, New Zealand, South Africa, etc., please follow local wiring regulations.

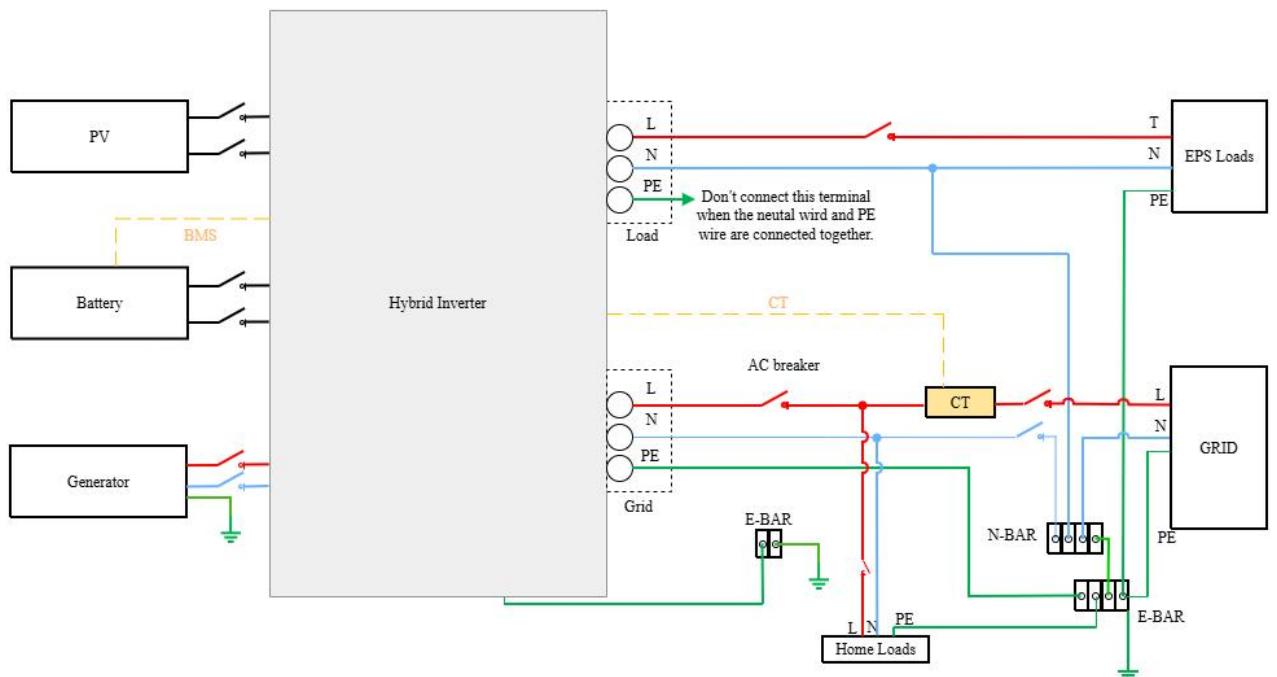

4.Operation

4.1 Power ON/OFF

Power ON:

1. Before powering on the inverter, verify that all wiring mentioned above is correct.
2. Switch on the DC breaker(Battery Side).
3. Switch on the DC breaker(PV Side).
4. Switch on the AC breaker.
5. Turn on the DC switch of the inverter and wait for the power to start.
6. After startup, the inverter will perform an initial self-check.
7. When the self-check is finished, proceed with the configuration steps described below.

Power OFF:

1. If you need to power off the inverter, first switch off the AC breaker.
2. Switch off the DC breaker(Battery Side).
3. Switch off the DC breaker(PV Side).
4. Turn off the DC switch.

There is residual voltage existing in the inverter after powering off, which needs 5 minutes to discharge. Wait at least 5 minutes before you make any operations.

4.2 Display Panel

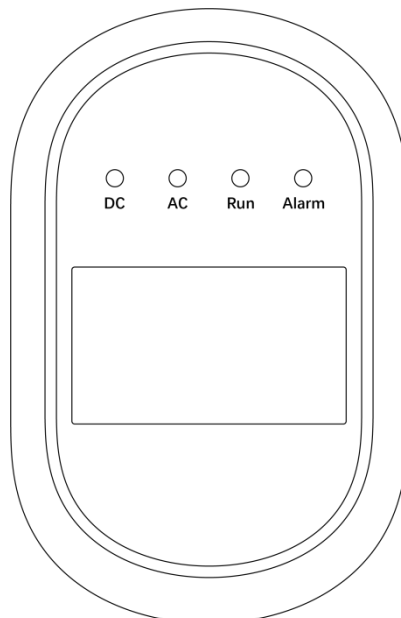

4.3 LED Indicators

Indicator	Color	Status	Meaning (Hybrid Run)	Meaning (AC-coupled Run)
DC	Green	Steady On	PV or Battery has power	Battery has power
		Off	Both PV and Battery have no power	Battery have no power
AC	Green	Steady On	Grid power available (Backup port energized)	Same
		Flashing	Grid lost (Backup port), self-check in progress (flashing)	Same
		Off	Grid + Backup + Generator ports all have no power	Same
Run	Green	Steady On	Normal operation	Same
		Flashing	Overload operation (flash frequency indicates load level)	Same
		Off	System stopped	Same
Alarm	Red	Steady On	In fault	Same
		Off	Normal running	Same
DC/AC/Run	Green	Flashing in order	Software updating is undergoing	Same

4.4 LCD Screen Interface

4.4.1 System Working Flow Chart

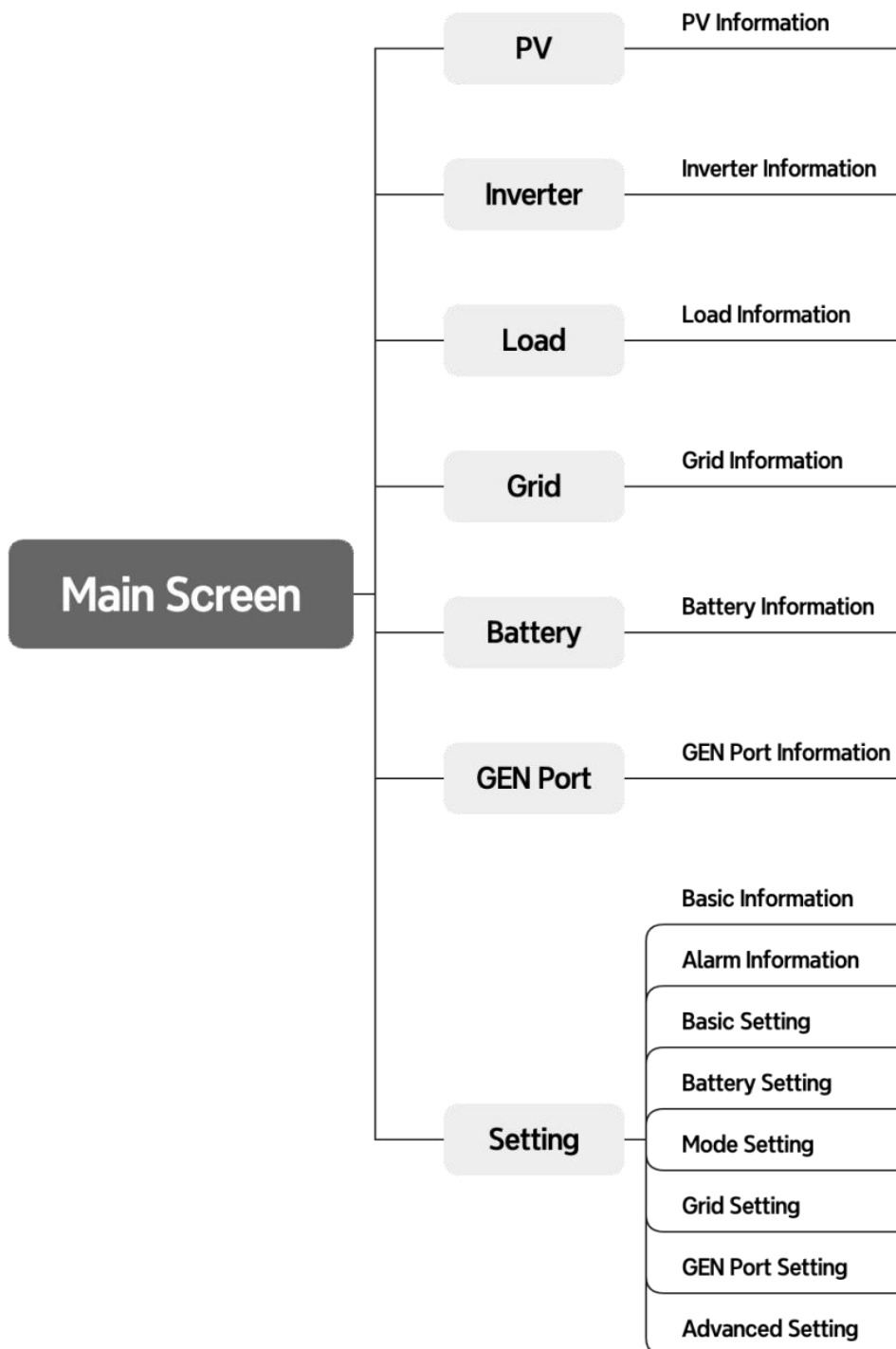

4.4.2 Display Information



The LT Hybrid Inverter intelligently manages energy from solar panels, the grid, batteries, and household loads to achieve optimal power utilization and efficiency. The display interface clearly shows real-time energy flow and power distribution, allowing users to understand system status at a glance.

The following describes the parameters shown in the example diagram. For detailed information, click the blue words (“Solar”, “Load”, “Battery”, “Grid”, “GEN”, etc.) to view more parameters.

- **Solar Generation: 8.6 kW**

The PV system generates 8.6 kW of clean solar power, serving as the primary energy source.

- **Load Consumption: 3.0 kW**

The household is currently consuming 3.0 kW of power.

- **Battery: 4.7 kW Charging (60%)**

The battery is charging at 4.7 kW with a state of charging (SOC) of 60%.

- **Grid Power: 0.9 kW export**

There is 0.9kW power exported to the grid.

- **Generator: 0.0 kW (Standby)**

The generator is currently inactive.

- **Smart Load:**

The smart load is currently inactive.

Note: Generator and smart load function share the same inverter port, so only one can be used at a time. Please choose the appropriate function based on your application scenario.

4.4.3 Parameters Setting

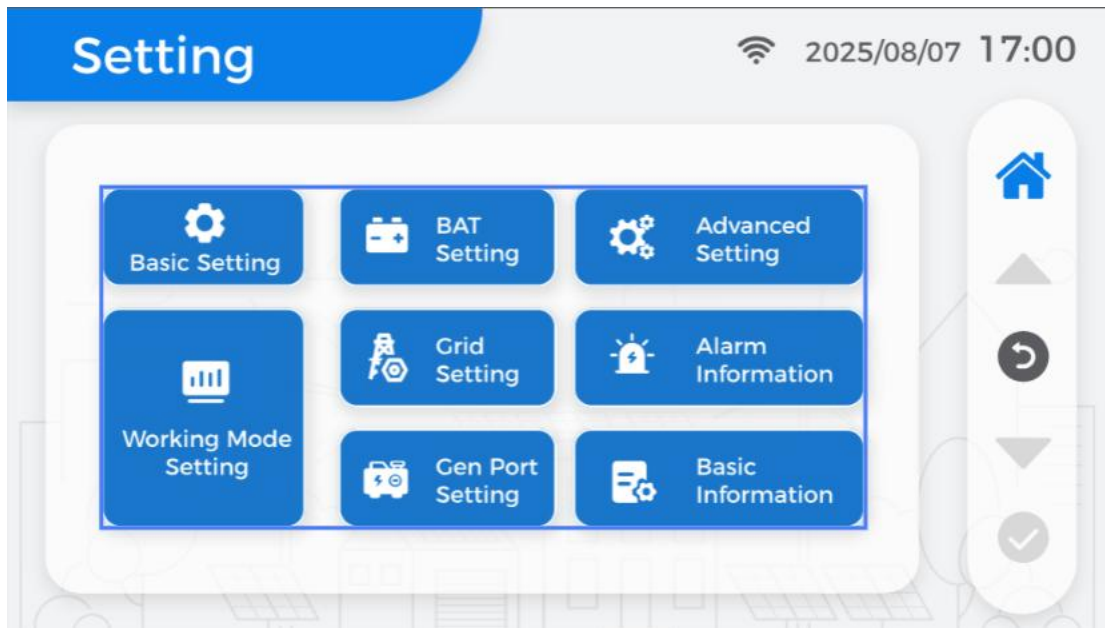

The **Setting Menu** provides access to all configuration and system management options of the LT Hybrid Inverter. Through this interface, users can adjust key parameters, view device information, and customize the inverter’s operation mode according to specific application needs.

4.4.4 Basic Setting

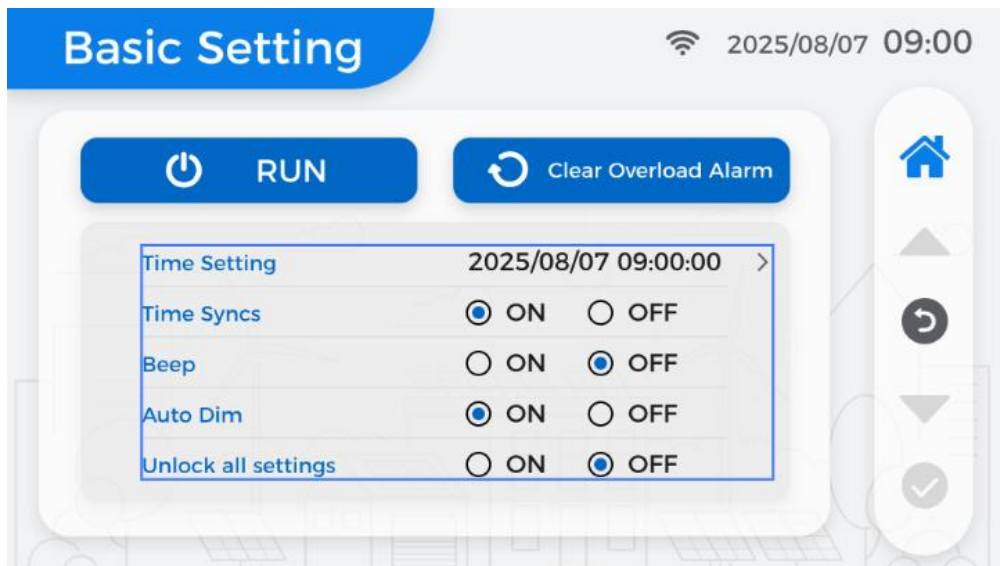

The **Basic Setting** menu allows users to adjust general system parameters such as time, display brightness, and audible alerts.

Users can set the system clock, enable or disable automatic time synchronization, turn the buzzer sound on or off.

This section also provides options to unlock all settings and clear overload alarms for quick maintenance or commissioning.

Notice: If your system only has the battery and load, you must touch the “RUN” button to power on the system. Otherwise, your system won't work normally.

Note: If you want to access any settings, you must first unlock the system by entering the password.

Steps:

1. Set **Unlock all settings** to **ON**.
2. Tap the √ button on the right side of the screen.
3. Enter the password **12345678**.
4. Tap **OK**.

After returning to **the setting menu**, settings will be available for configuration.

4.4.5 Battery Setting

The hybrid inverter supports three types of batteries: **Lithium**, **Lead-acid** and **None**. Users must select the correct battery type before configuring parameters.

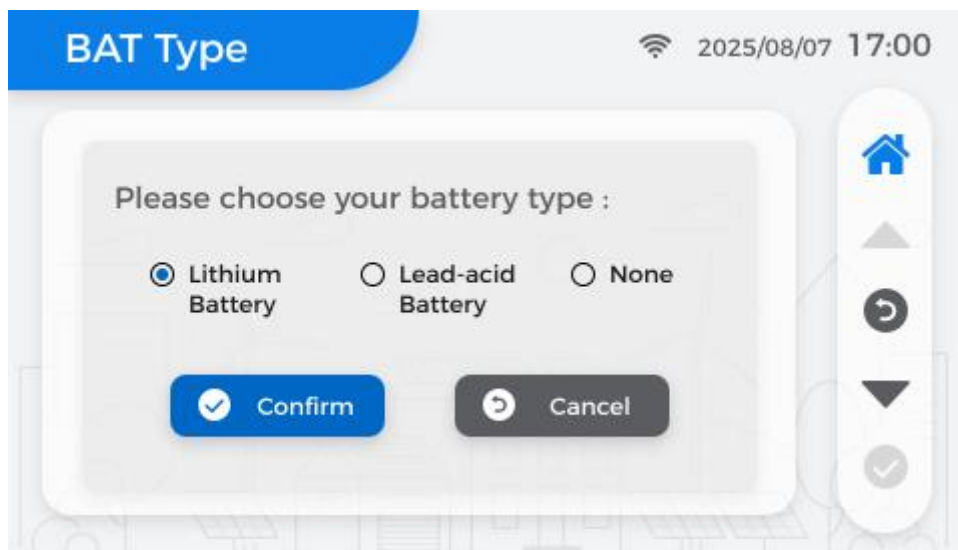

- **None**
Please select the 'None' to avoid the alarm when your system doesn't have the battery.
- **Lithium/Lead-acid Battery Settings**

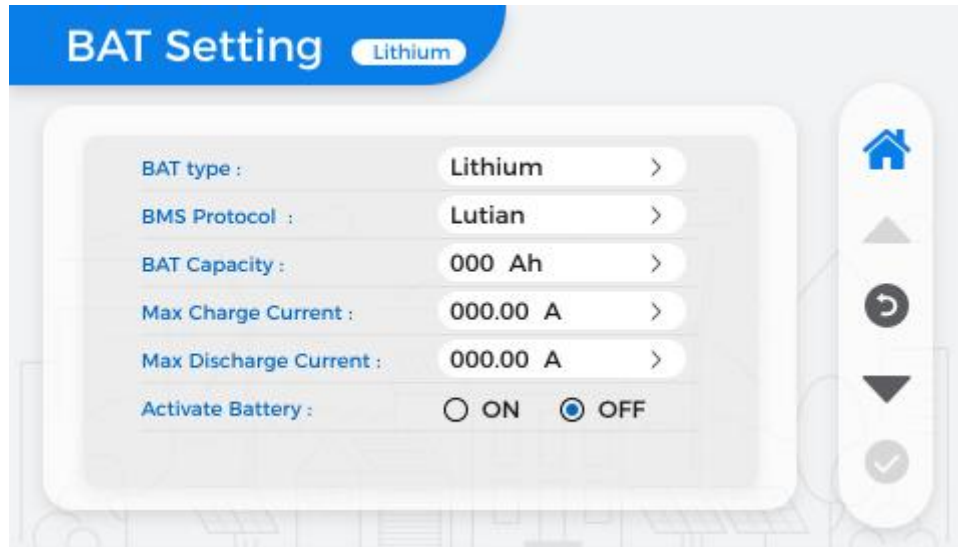

- **Battery Type:** Select *Lithium* or *Lead-acid*.
- **BMS Protocol:** Choose the corresponding protocol for the battery (Lutian/ Pylontech-LV-CAN/ AGM/ GEL) .
- **Battery Capacity (Ah):** Enter the rated capacity of the battery.
- **Max Charge Current / Max Discharge Current:** Set according to the battery specification sheet.
- **Activate Battery:** Switch *ON* to enable the battery, *OFF* to disable.

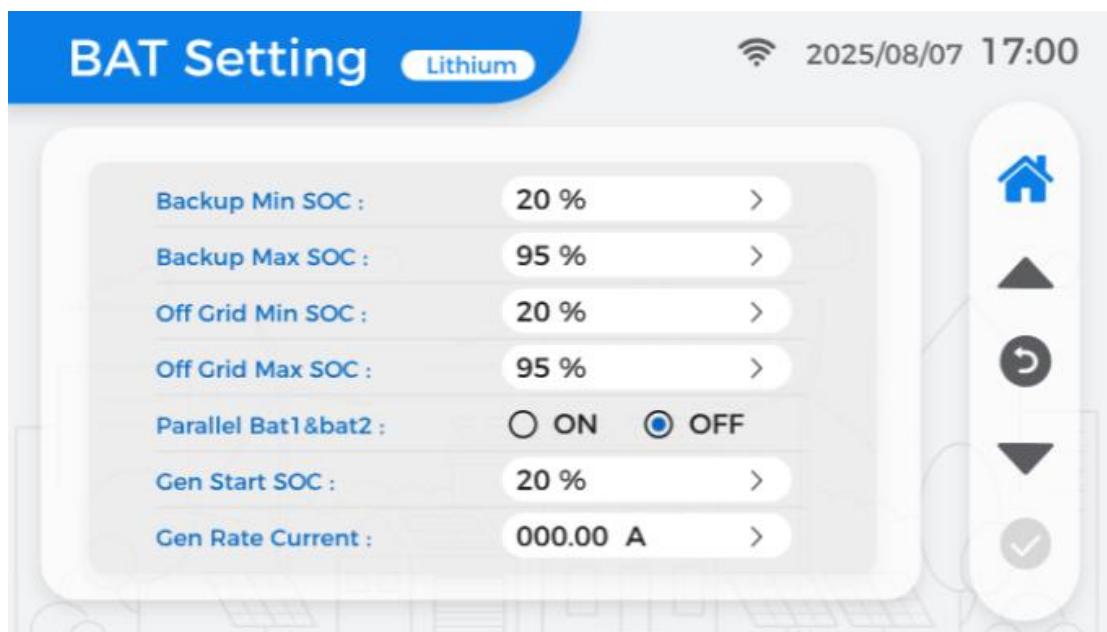

- **Backup Min/Max SOC:** Define the SOC range for backup operation (e.g., 20%–95%).
- **Off-Grid Min/Max SOC:** Define the SOC range for off-grid operation.
- **Parallel Bat1 & Bat2:** Enable if two batteries are connected in parallel.
- **Generator Start SOC:** Set the SOC threshold at which the generator will start automatically.

- **Generator Rate Current:** Define the charging current supplied by the generator.

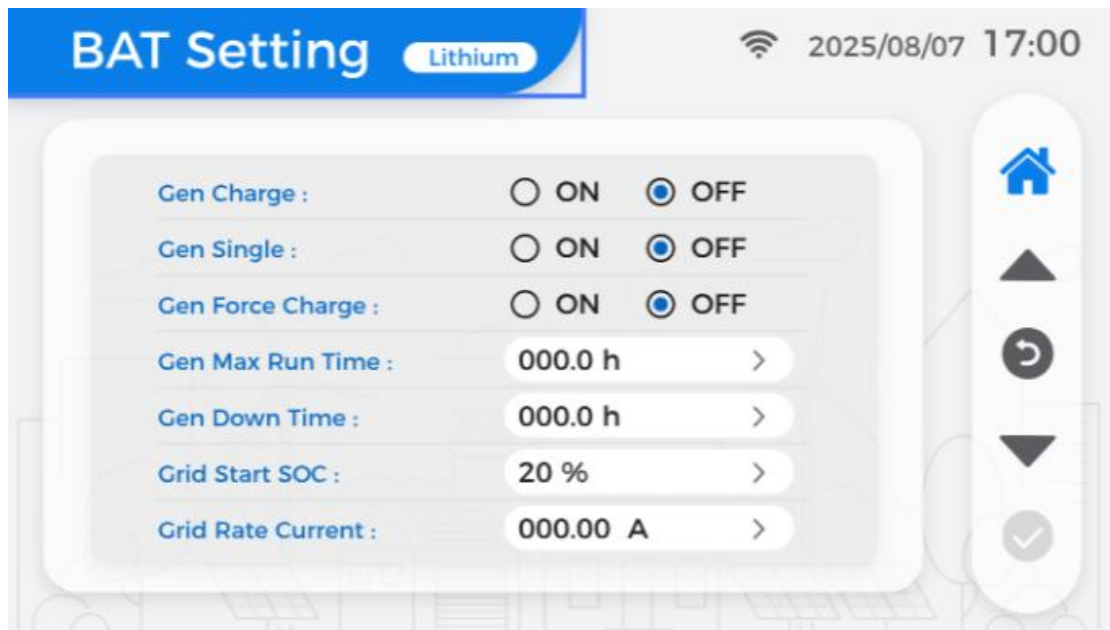

- **Gen Charge:** Enable/disable generator charging.
- **Gen Single:** Enable/disable generator standalone operation.
- **Gen Force Charge:** Force the generator to charge regardless of SOC.
- **Gen Max Run Time:** Maximum continuous generator runtime.
- **Gen Down Time:** Minimum interval between generator runs.
- **Grid Start SOC:** SOC threshold to trigger grid charging.
- **Grid Rate Current:** Define the charging current supplied by the grid.

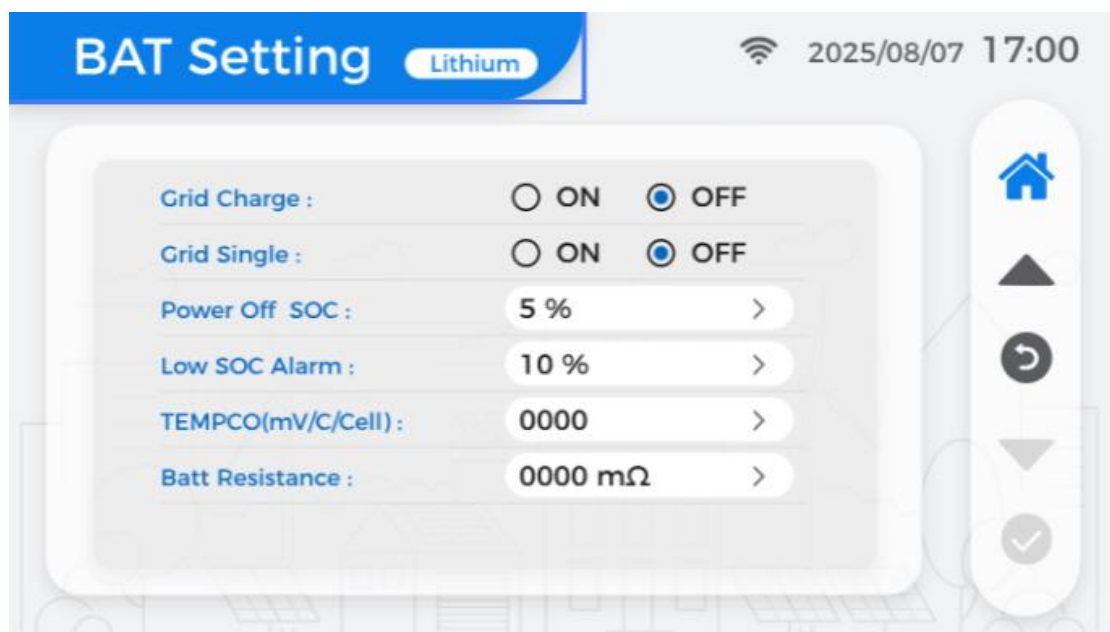

- **Grid Charge:** Enable/disable grid charging.
- **Grid Single:** Enable/disable grid standalone operation.
- **Power Off SOC:** SOC threshold at which the system shuts down.

- **Low SOC Alarm:** SOC threshold to trigger a low battery alarm.
- **TEMPCO (mV/°C/Cell):** Temperature compensation coefficient.
- **Battery Resistance (mΩ):** Input the internal resistance of the battery.

- **Additional Battery Settings**

The lithium battery configuration is now complete. For lead-acid batteries, please proceed with the settings below.

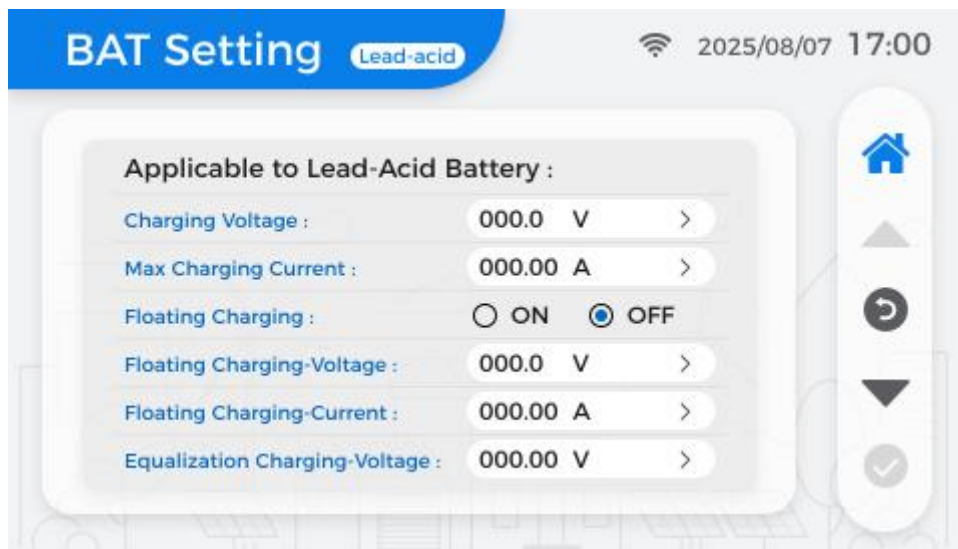

- **Battery Type:** Select *Lead-acid*.
- **Charging Voltage:** Set the charging voltage according to the battery specification.
- **Max Charging Current:** Define the maximum allowable charging current.
- **Floating Charging:** Enable/disable float charging.
- **Floating Charging Voltage / Current:** Set float charging parameters.
- **Equalization Charging Voltage:** Set the equalization charging voltage.

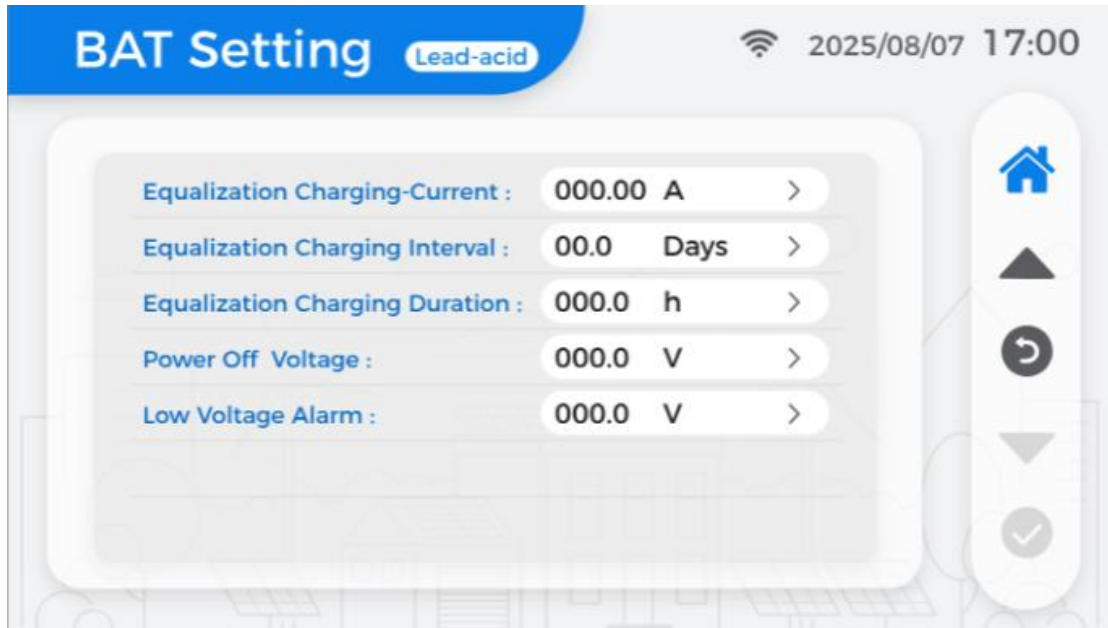

- **Equalization Charging Current:** Define the current during equalization charging.
- **Equalization Charging Interval (Days):** Set the interval between equalization cycles.
- **Equalization Charging Duration (Hours):** Define the duration of each equalization cycle.
- **Power Off Voltage:** Voltage threshold at which the system shuts down.
- **Low Voltage Alarm:** Voltage threshold to trigger a low battery alarm.

4.4.6 Mode Setting

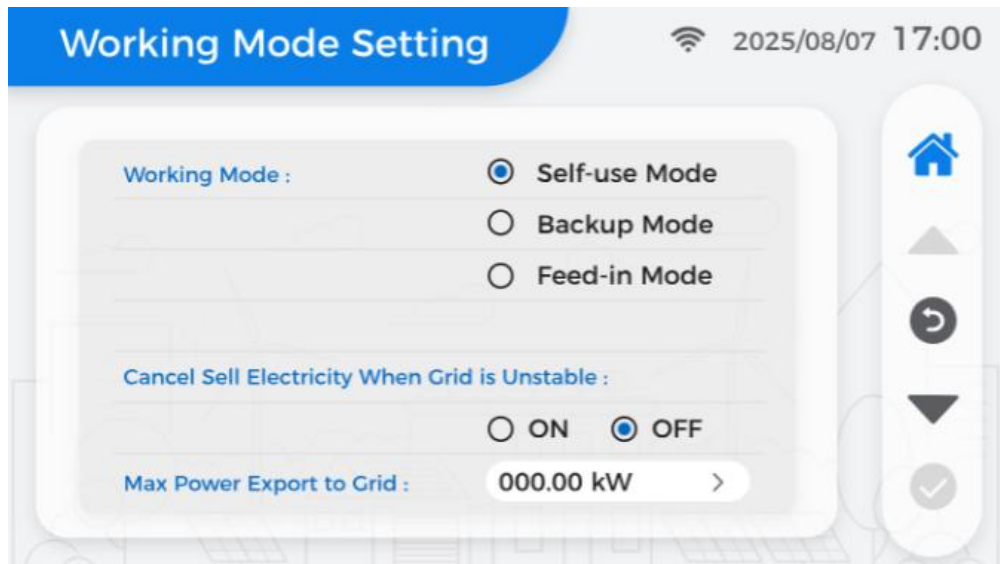

This screen allows the user to select the overall operating mode of the inverter and configure grid export behavior.

- **Working Mode Options:**

- **Self-use Mode:** Prioritizes local consumption of PV energy. Excess energy is stored in the battery or exported to the grid.
- **Backup Mode:** Prioritizes battery charging to ensure backup power availability.
- **Feed-in Mode:** Prioritizes local consumption of PV energy. Excess energy is exported to the grid.
- **Cancel Sell Electricity When Grid is Unstable:**
 - *ON:* Stops exporting power to the grid when instability is detected.
 - *OFF:* Continues exporting regardless of grid stability.
- **Max Power Export to Grid (kW):** Defines the maximum power that can be exported to the grid.

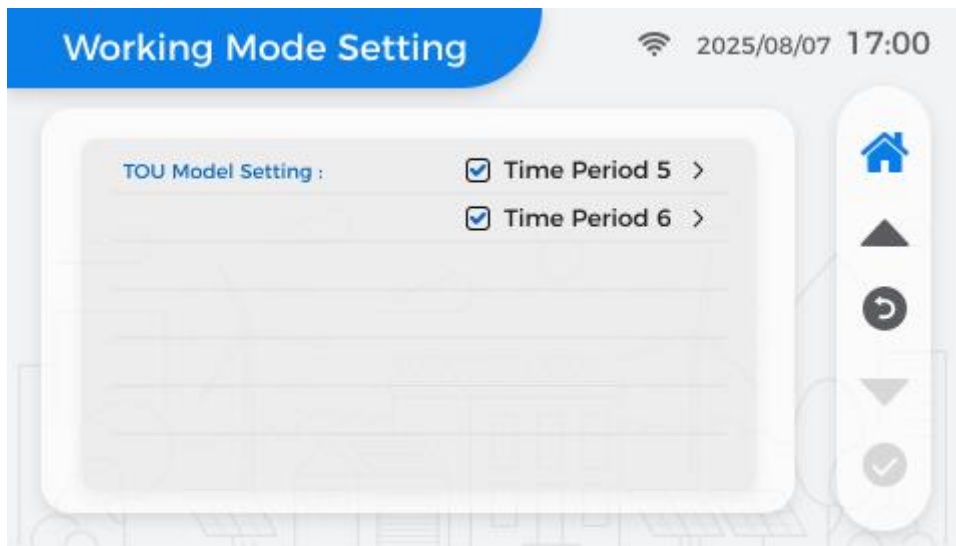
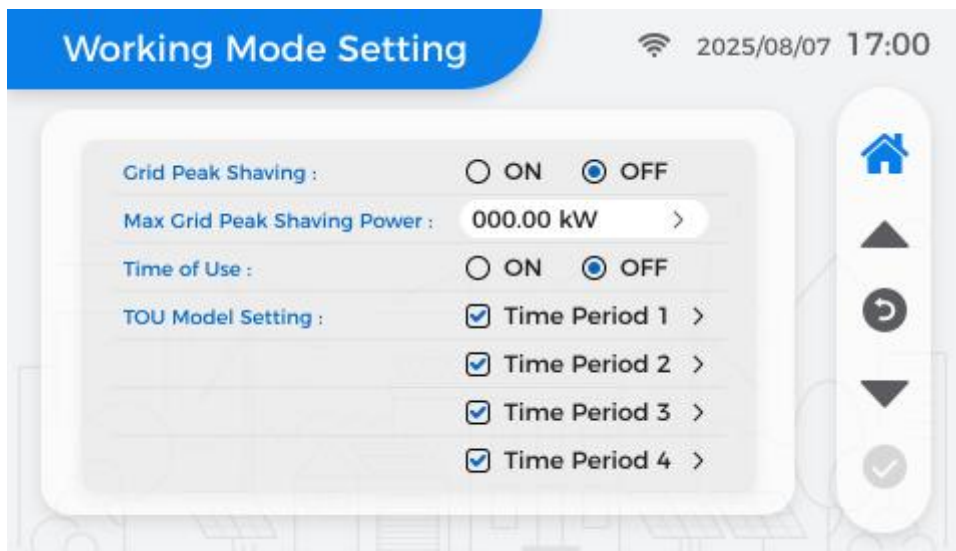

This screen allows the user to optimize energy usage based on grid demand and electricity pricing.

- **Grid Peak Shaving:**
 - *ON:* Limits grid power consumption during peak demand periods.

- *OFF*: No limitation on grid power usage.
- **Max Grid Peak Shaving Power (kW)**: Sets the maximum grid power that can be drawn during peak shaving.
- **Time of Use (TOU)**:
 - *ON*: Enables Time Of Use scheduling.
 - *OFF*: Disables Time Of Use scheduling.
- **TOU Model Setting**: Allows configuration of up to six time periods (Period 1–6), each with different charging/discharging strategies according to electricity tariffs.
 - **Time Period**: Determine the operating time for the current period based on the selected month, week, hour, minute settings.
 - **Charge**: Battery charges during this time period.
 - **Grid/Gen**: Enable battery charging from the grid or generator.
 - **Discharge**: Battery discharges during this time period.
 - **Power**: Max. charge/discharge power of the battery.
 - **Voltage**:The target voltage of the lead-acid battery.Once the target value is reached, the battery stops charging/discharging.
 - **SOC**:The target SOC of the lithium battery. Once the target value is reached, the battery stops charging/discharging.

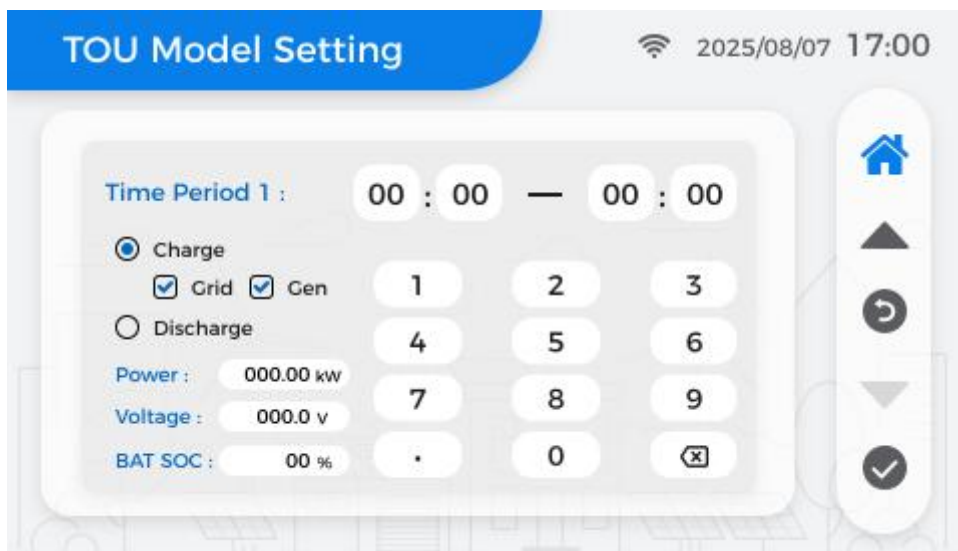
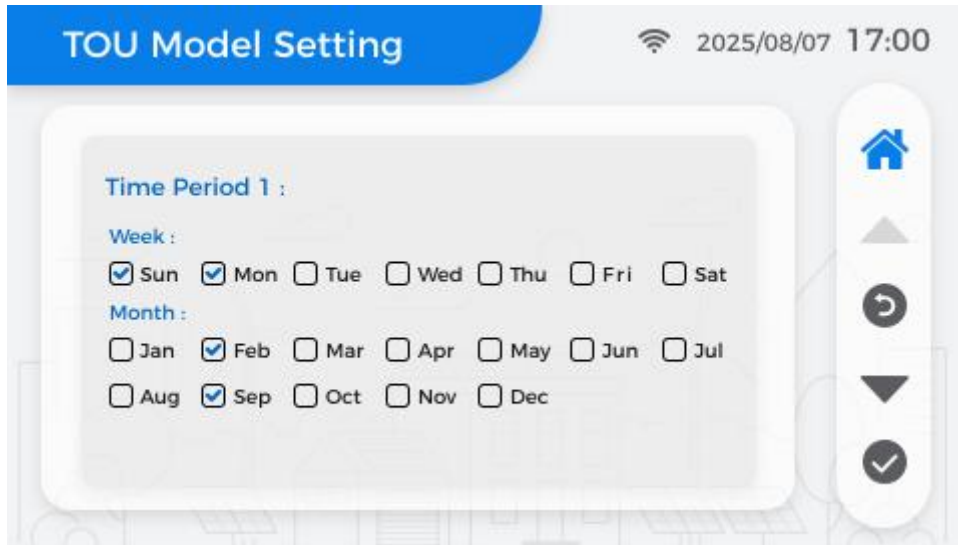

4.4.7 Grid Setting

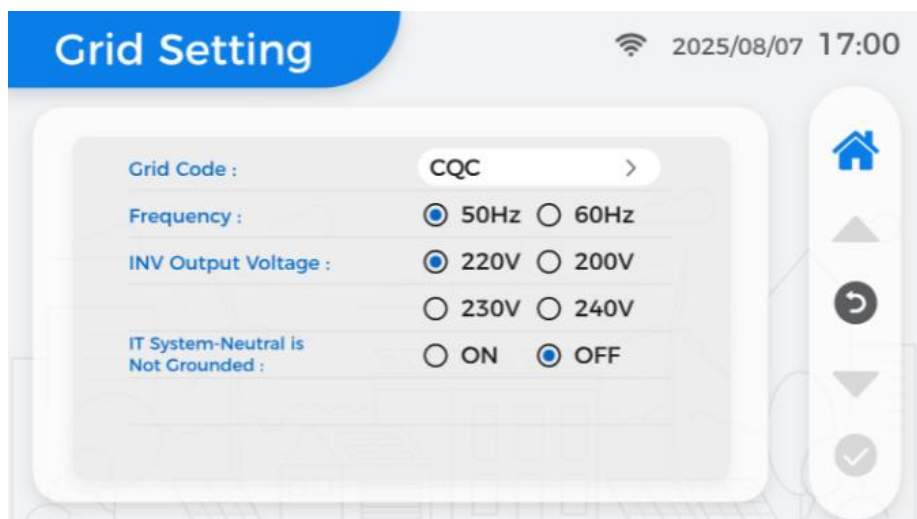

This screen allows the user to configure grid-related parameters to ensure compatibility and safe operation with the local utility network

- **Grid Code:** Select the appropriate grid standard (e.g., CQC).
- **Frequency:** Choose between 50 Hz or 60 Hz according to the local grid.
- **Inverter Output Voltage:** Set the output voltage (200 V / 220 V / 230 V / 240 V).
- **IT System – Neutral Not Grounded:** Enable or disable depending on the grounding method of the installation.

4.4.8 GEN Port Setting

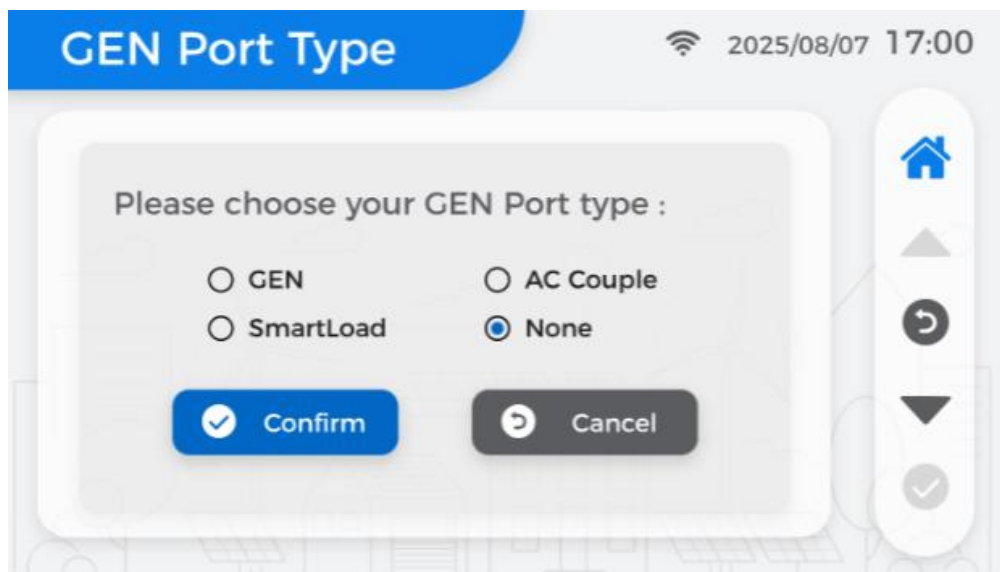

The **GEN Port** of the hybrid inverter is a multifunctional AC port that can be configured for different purposes depending on the system design and user requirements.

It supports **four operating modes: Generator, AC Coupling, Smart Load, and None.** This flexibility allows the inverter to adapt to various applications efficiently.

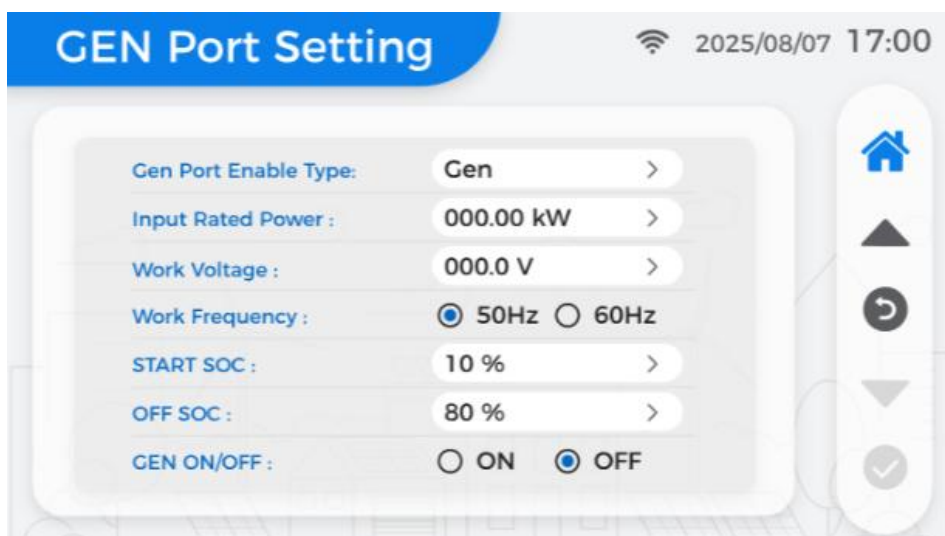

When the **GEN** mode is selected, the inverter can automatically control the generator based on system parameters:

- **Gen Port Enable Type:** Shows the selected mode (GEN).
- **Input Rated Power:** Displays the generator's rated power. Set according to the actual generator capacity.
- **Work Voltage:** Indicates the input voltage from the generator when running.
- **Work Frequency:** Select between **50 Hz** or **60 Hz** depending on regional standard.
- **Start SOC:** When battery SOC drops below this value, the inverter sends a start signal to the generator.
- **Off SOC:** When battery SOC reaches this value, the inverter sends a stop signal to the generator.
- **GEN ON/OFF:** Manually start/stop the generator.

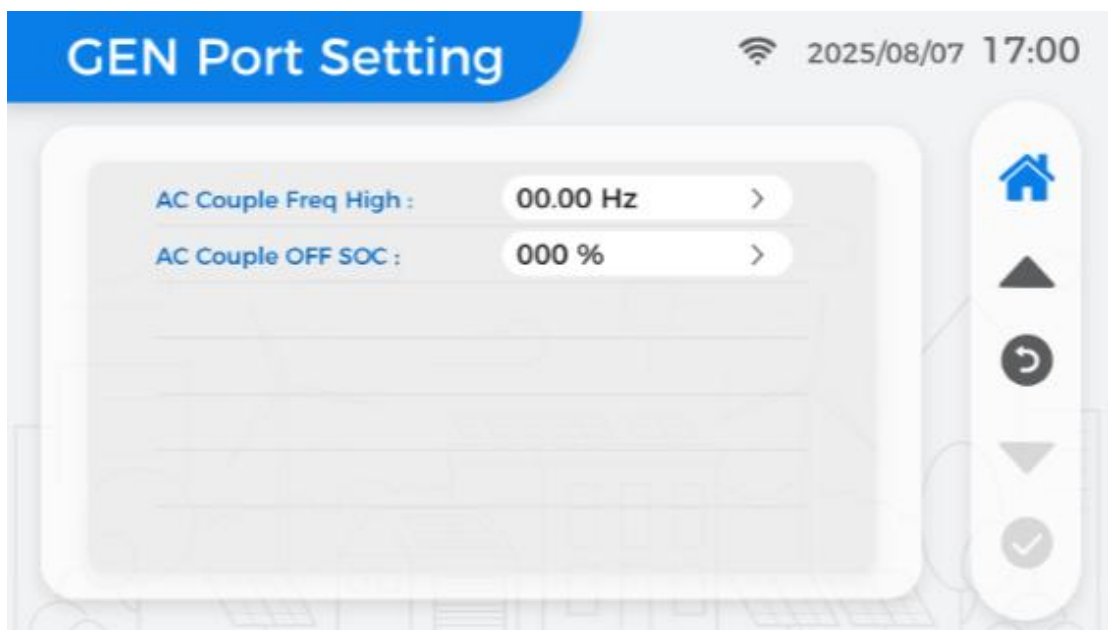

When **AC Couple** mode is enabled, the GEN Port connects to a grid-tied inverter to expand solar generation or retrofit existing PV systems.

AC Couple Freq High: Defines the upper frequency limit at which the hybrid inverter limits the AC-coupled inverter's output. This ensures system stability and prevents overcharging.

AC Couple OFF SOC: Sets the battery SOC threshold at which the AC-coupled inverter output is turned off to avoid overcharging.

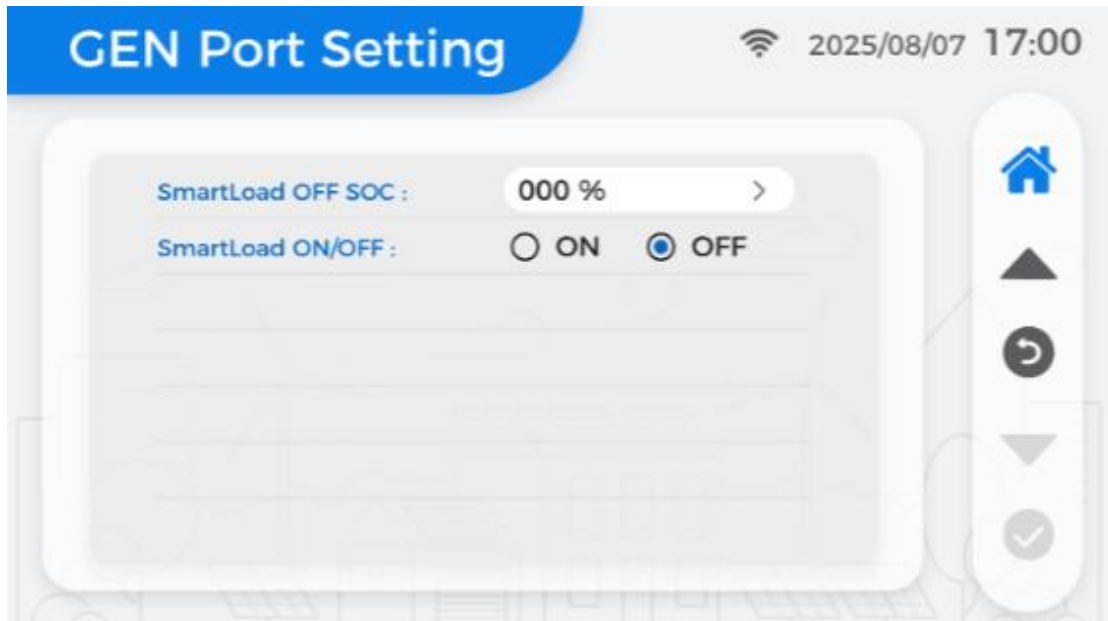

When **Smart Load** mode is selected, the GEN Port can supply specific high-power appliances that should only run when energy is abundant.

Smart Load OFF SOC: Defines the minimum battery SOC at which the smart load is automatically disconnected to protect battery capacity.

Smart Load ON/OFF : Manually enable or disable the smart load output.

4.4.9 Advanced Setting

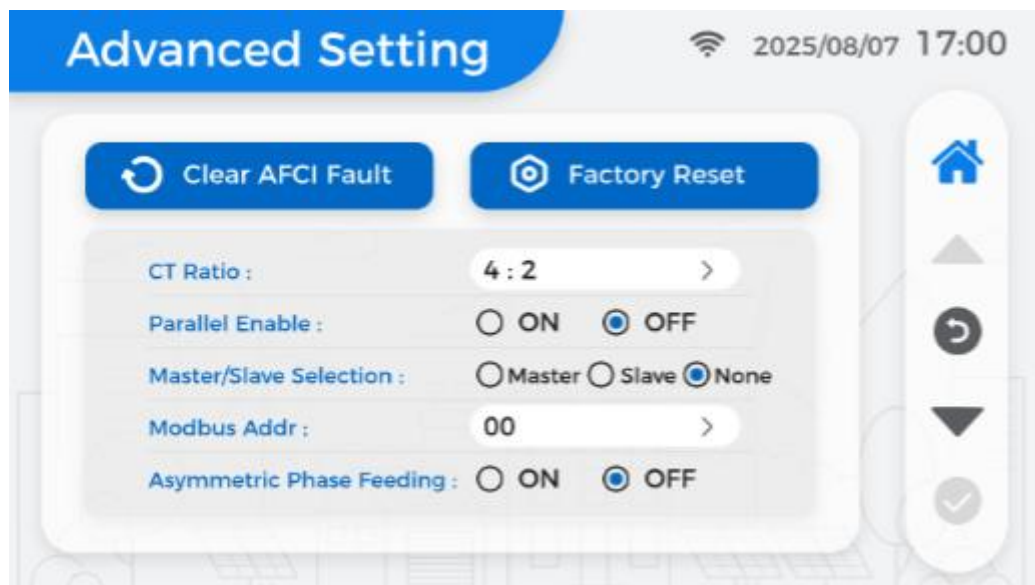

- **Clear AFCI Fault:** Resets Arc Fault Circuit Interrupter (AFCI) alarms. Use after resolving the root cause of the fault.
- **Factory Reset:** Restores all parameters to factory defaults. Use with caution—this erases custom settings.
- **CT Ratio:** Sets the ratio for current transformer (CT) measurement. Must match the installed

CT specification.

- **Parallel Enable:** Enables or disables parallel operation with other units.
- **Master/Slave Selection:** Defines the role of the unit in a parallel system.
- **Modbus Addr:** Assigns a unique Modbus communication address for monitoring/control.
- **Asymmetric Phase Feeding:** Allows unbalanced load distribution across phases.

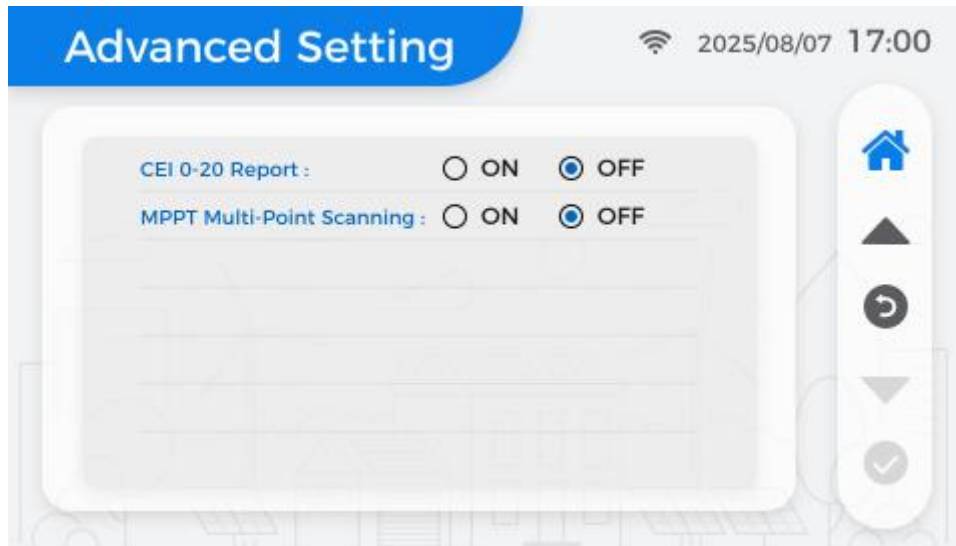

- **CEI 0-20 Report:** Enables reporting according to CEI 0-20 standard (regional compliance).
- **MPPT Multi-Point Scanning:** Activates advanced Maximum Power Point Tracking (MPPT) scanning for variable solar conditions. May slightly reduce efficiency during scanning.

5. Maintenance



Warning: Improper maintenance may cause electric shock or equipment damage. Only qualified personnel should perform internal inspections or repairs.



Caution: Be careful to touch the inverter while it is operating. Some parts may be hot and may cause burns.



Caution: Turn OFF the inverter and wait it to cool down before cleaning or performing any inspections.



Caution: Never use any liquids, solvents, or corrosive materials for cleaning.



Caution: Only professional or qualified electricians are allowed to open the inverter covers.

5.1 Routine Care

The inverter does not require frequent maintenance.

However, keeping the inverter clean helps it work efficiently and last longer.

- Use a **soft, dry brush or cloth** to remove dust from the surface and heat sink.
- Do **not** use water, spray cleaners, or strong solvents.
- Make sure the ventilation openings are clear to ensure proper cooling.

5.2 Safety Notes for Maintenance

Caution:

Do not touch the inverter while it is operating. Some parts may be hot and can cause burns.

Turn **OFF** the inverter and allow it to cool down before cleaning or performing any checks.

Note:

Never use any liquids, solvents, or corrosive materials for cleaning.

Only qualified electricians should open the inverter cover.

6. Troubleshooting

Fault Code	Description	Recommended Troubleshooting
1	Utility Loss	<p>1. Check whether the grid is abnormal.</p> <p>2. Check whether the AC cable is connected correctly.</p> <p>3. Restart the inverter to check if the fault still exists.</p>
2	Grid phase overvoltage protection	
3	Grid line overvoltage protection	
4	Peak overvoltage protection	
5	Grid phase undervoltage protection	
6	Grid line undervoltage protection	
7	10-minute overvoltage protection	
8	LVRT undervoltage	
9	HVRT overvoltage	
10	Grid voltage unbalance	
11	Grid waveform overvoltage fault	
12	Grid waveform undervoltage fault	
13	Grid rapid outage protection	
14	Grid overfrequency protection	
15	Grid underfrequency protection	
16	Grid frequency instability protection	
17	Grid phase instability protection	
18	Anti-islanding protection	
19	Grid phase loss protection	
20	Grid phase sequence abnormal fault	
21	Neutral line loss (Split phase)	
1001	PV input overvoltage	Restart the inverter to check if the fault still exists.
1004	PV input overcurrent	Restart the inverter to check if the fault still exists.
1002	PV continuous hardware overcurrent	Check whether the PV wiring is correct and not loose.
1005	PV string connect reversed	Check if the PV wiring is reversed
1006	PV string unconnected	Check whether the PV wiring is correct and not loose.
2001	Battery input hardware overcurrent	Check whether the battery wiring is correct and not loose.
2007	Battery low voltage power-off protection in back-up mode	Check battery SOC and recharge immediately.
2008	Battery abnormal connection	<p>Inspect battery terminals and communication cables. Ensure polarity is correct and connectors are firmly secured. Check for broken or oxidized terminals.</p>
2009	Battery abnormal disconnection	
2013	Battery input reversed	
2010	Battery precharge fault	Restart battery and inverter.
2011	Battery relay fault	

2012	Battery input overvoltage	Confirm the battery system voltage matches inverter specifications. Avoid charging above maximum voltage.
2014	Battery charger overvoltage	
3001	Back-up output overload	Reduce connected load or limit surge devices (motors, air conditioners).
3004	Connect box failure	Check wiring between inverter and connection box, restart system.
4002	External fan abnormal	Check fan connection, clean dust, or replace fan if necessary.
5001	AC terminal overtemperature	No need to deal with it, the device is in normal operation.
5002	Cavity overtemperature	No need to deal with it, the device is in normal operation.
6012	Relay device failure	Internal relay test failed. Power off inverter, wait for cooling, and restart. If recurring, contact after-sales service
6013	DC arc fault	Immediately power off the inverter and inspect PV wiring, connectors, and insulation. Do not restart until cause is removed.
7001	Abnormal GFCI 30mA	Measure insulation resistance and inspect for grounding faults on PV side or AC output.
7002	Abnormal GFCI 60mA	
7003	Abnormal GFCI 150mA	
7004	Abnormal GFCI	
7006	DCI L2 protection	Check grid grounding and connection stability. If recurring, measure DC component on AC line and inspect inverter grounding.
7007	Low insulation resistance	Test PV strings and battery cables for leakage to ground.
7008	Abnormal ground.	Ensure correct PE connection and system bonding.
7009	L-PE short circuit	Immediately disconnect AC input and output, inspect wiring insulation.
7011	DCV L2 protection	Check the input voltage from PV or battery. Ensure it does not exceed the maximum DC voltage specified in the datasheet.
7012	Hardware anti-backflow protection	If triggered repeatedly, check grid wiring and CT/meter configuration.
7013	GFCI multiple failures	Inspect for persistent insulation degradation or water ingress. Contact

		support if not resolved.
7014	AFCI multiple failures	Check connectors, cables, and terminals.
7015	CT Loss	Check CT wiring, direction, and ensure correct terminal connection.

Table above shows the fault codes and the corresponding descriptions, along with their solutions. Furthermore, warnings are usually triggered by external conditions and do not interfere with the normal operation of the machine. If the machine frequently reports faults and affects its normal operation, it is recommended that you contact the after-sales service.

7. Specification

Models	Ei.H008KL-A1.23-P1NV	Ei.H010KL-A1.23-P1N V	Ei.H012KL-A1.34-P1N V
PV input data			
Recommend max. PV capacity (W)	16000	20000	24000
Max. PV input power (W)	12800	16000	19200
Max. PV input voltage (V)	600	600	600
Rated voltage (V)	360	360	360
Start voltage (V)	62	62	62
MPPT voltage range (V)	65-550	65-550	65-550
Max. PV input current (A)	40/20	40/20	40/20/20
Max. short-circuit current per MPPT (A)	50/30	50/30	50/30/30
Max. Inverter backfeed current to the array (A)	0	0	0
MPPT number	2	2	3
NO. of PV strings per MPPT	2/1	2/1	2/1/1
Battery input data			
Battery type	Li-ion/Lead-acid	Li-ion/Lead-acid	Li-ion/Lead-acid
Battery voltage range (V)	40~60	40~60	40~60
Max. charging current (A)	160	200	240
Max. discharging current (A)	160	200	240
AC output/input Data (grid side)			
Rated output power (W)	8000	10000	12000
Max. continuous output power (VA)	8800	11000	13200
Rated output current (A)	36.4/34.8	45.5/43.5	54.5/52.2
Max output current (A)	40/38.3	50/47.8	60/57.4
Inrush current (A)	2.2	2.2	2.2
Max. output fault current (A)	144A/2us		
Max. Output overcurrent protection (A)	144A/2us		
Max. input power (W)	12000	15000	18000
Max. input current (A)	54.5/52.2	68.2/65.2	81.8/78.3
Operation phase	L+N+PE		
Rated output voltage (V)	220/230		
Rated frequency (Hz)	50/60		

THDi	<3%		
Power factor	1 (0.8leading~0.8lagging)		
AC output (backup)			
Rated output power (W)	8000	10000	12000
Peak power (VA,s)	16000, 10	20000, 10	24000, 10
Rated output current (A)	36.4/34.8	45.5/43.5	54.5/52.2
Rated output voltage (V)	220/230		
Rated frequency (Hz)	50/60		
Switch time (ms)	<10		
Generator data			
Rated input power (W)	8000	10000	12000
Max. apparent input power (VA)	11000	12000	12000
Max. input current (A)	50/47.8	54.5/52.2	54.5/52.2
Rated input voltage (V)	220/230		
Rated frequency (Hz)	50/60		
Efficiency			
Max. efficiency	97.60%	97.60%	97.60%
EU efficiency	97.00%	97.00%	97.00%
Protection			
DC switch	Yes		
DC reverse-polarity connection protection	Yes		
Thermal protection	Yes		
AC overvoltage/current protection	Yes		
AC short circuit protection	Yes		
Ground fault circuit interrupter	Yes		
Power network monitoring	Yes		
Island protection	Yes		
Ground fault monitoring	Yes		
Insulation resistance monitoring	Yes		
Residual current detection	Type B		
PID recovery	Optional		
Arc fault circuit interrupter	Optional		
Surge protection	AC TypeII/DC TypeII		
General			
Dimensions (WxHxD mm)	426*630*241		

Weight (kg)	31
Noise (dB)	<45
Operating temperature (°C)	-25~60 (>45°C derating)
Type of cooling	Smart air cooling
Topology	Transformless
Communication	RS485/CAN
Permissible altitude (m)	3000 (>2000m derating)
Permissible ambient humidity	0~100%
Pollution degree	III
Ingress protection (IP) grade	IP66
Warranty	5/10 years; (More info refers to the warranty policy)
Display	LCD+LED